



SWISSLION INDUSTRIJA ALATA TREBINJE, BOSNA I HERCEGOVINA, PROIZVODI REZNI ALAT VEĆ VIŠE OD 55 GODINA. STEČENO ISKUSTVO, PRIMJENA NAUKE I MODERNIH TEHNOLOŠKIH POSTIGNUĆA, OMOGUĆILI SU SL IAT DA POSTANE NAJVEĆI PROIZVOĐAČ VISOKO KVALITETNIH ALATA U BOSNI I HERCEGOVINI I JEDAN OD NAJVEĆIH U EVROPI. PODATAK DA SE 40 MILIONA KOMADA ALATA GODIŠNJE PRODA U VIŠE OD 40 ZEMALJA SVIJETA, DAJE ČVRSTU GARANCIJU KVALITETA SL IAT PROIZVODA I PROIZVODNIH MOGUĆNOSTI.

ALATI SE PROIZVODE OD NAJKVALITETNIJIH ČELIKA (MOLIBDENSkih, KOBALTNih I DRUGIH LEGIRANIH BRZOREZNIH ČELIKA).

DANAS SL IAT IMA ŠIROK PROIZVODNI PROGRAM:

- ALAT ZA BUŠENJE (OD BRZOREZNOG ČELIKA, SA PLOČICOM OD TM I KOMPLET OD TM),
- ALAT ZA REZANJE NAVOJA (OD BRZOREZNOG ČELIKA),
- KONTROLNI ALAT ZA NAVOJ I RUPU,
- ŠTRUGARSKI ALAT (OD BRZOREZNOG ČELIKA ILI SA PLOČICOM OD TM),
- KRUŽNE TESTERE ZA REZANJE METALA,
- GLODALA,
- ČEOŃA VREtenASTA GLODALA,
- UPUŠTAČE,
- RAZVRTAČE,
- ALAT ZA RUDARSTVO,
- PRIBOR ZA MAŠINE.

OVAJ PRIKAZ PROIZVODNOG PROGRAMA JE NAVEDEN DA BI NAŠIM KUPCIMA OMOGUĆIO UVID U NAŠE TEHNOLOŠKE MOGUĆNOSTI, JER KATALOG - CJENOVNIK N° 6, KOJI JE NAMIJENJEN EVROPSKOM TRŽIŠTU, DEFINIŠE SAMO DIO NAŠEG PROIZVODNOG PROGRAMA.

THE CUTTING TOOL FACTORY SWISSLION INDUSTRIJA ALATA TREBINJE, BOSNIA AND HERZEGOVINA HAS BEEN MANUFACTURING TOOLS FOR MORE THAN 55 YEARS. ACCUMULATED EXPERIENCE, APPLICATION OF SCIENCE AND UP TO DATE TECHNOLOGICAL ACHIEVEMENTS ENABLED SL IAT TO BECOME THE LARGEST HIGH QUALITY TOOL MANUFACTURER IN BOSNIA AND HERZEGOVINA AND ONE OF THE LARGEST IN EUROPE. THE NUMBER OF 40 MILION PIECES OF SOLD TOOL PER YEAR IN MORE THAN 40 COUNTRIES IN THE WORLD GIVES A FIRM CONFIRMATION OF SL IAT HIGH QUALITY TOOLS AND ITS PRODUCTION POSSIBILITIES.

THE TOOLS ARE MANUFACTURED FROM THE BEST QUALITY STEELS ( MOLYBDENUM, COBALT AND OTHER ALLOY HIGH SPEED STEELS).

AT PRESENT SL IAT HAS A WIDE PRODUCTION PROGRAMME:

- BORING TOOL (HSS, CARBIDE TIPPED OR SOLID CARBIDE),
- THREAD CUTTING TOOL (HSS),
- THREAD ROLLING TOOL,
- THREAD GAGES AND BORE GAGES,
- LATHE TOOL (HSS OR CARBIDE TIPPED),
- METAL CUTTING CIRCULAR SAWS,
- MILLING CUTTERS,
- END MILLS,
- COUNTERSINKS, COUNTERBORES,
- REAMERS,
- MINING TOOLS,
- TOOL MACHINE ACCESSORIES.

THIS PRODUCTION PROGRAMME LIST IS MADE IN ORDER TO GIVE OUR CUSTOMERS AN INSIGHT INTO OUR TECHNOLOGICAL CAPABILITIES, FOR IN THIS PRICE LIST N° 6 MADE FOR EUROPEAN MARKET, ONLY A PART OF SL IAT PRODUCTION PROGRAMME IS INCLUDED.

PRÄZISIONSWERKZEUGFABRIK SWISSLION INDUSTRIJA ALATA TREBINJE, BOSNIA UND HERZEGOVINA STELLT DIE WERKZEUGE SEIT MEHR ALS 55 JAHREN HER AKKUMULIERTE ERFAHRUNG, ANGEWANDTE WISSENSCHAFT UND ZEITGEMÄSSIGSTERE TECHNOLOGISCHE SPITZENLEISTUNGEN ERMÖGLICHTEN DER SL IAT UM DER GRÖSSTE HERSTELLER DER HOCHLEISTUNGWERKZEUGE IN BOSNIA UND HERZEGOVINA UND EINER DER GRÖSSTEN IN DER WELT ZU WERDEN. DIE STÜCKZAHL VON 40 MIO, DIE IM EINEN JAHRE IN MEHR ALS 40 LÄNDERN IN DER WELT VERKAUFT WURDEN, GIBT DIE BESTE ANERKENNTNIS DER HOHEN QUALITÄT DER SL IAT WERKZEUGE UND IHRER HERSTELTMÖGLICHKEITEN.

DIE WERKZEUGE WERDEN AUS HOCHLEISTUNGSSCHNELLSTÄHLE (MOLYBDÄŃ, KOBALT, UND ANDERE HOCHLEISTUNGSSTÄHLE) HERGESTELLT.

SL IAT HAT HEUTE EIN BREITES HERSTELLUNGSPROGRAMM:

- SPIRALBOHRER (AUS HSS, MIT HARTMETALLPLÄTCHTEN ODER AUS HARTMETALL),
- GEWINDEBOHRER (AUS HSS),
- GEWINDEROLLWERKZEUGE,
- LEHREN,
- DREHMEISSEL (AUS HSS UND MIT HARTMETALLPLÄTCHTEN),
- METALLKREISSÄGEN,
- FRÄSER,
- REIBAHLEN,
- SENKER,
- BERGBAUWERKZEUGE,
- WERKZEUGMACSINEN UND VORRICHTUNGEN.

DAS OBEN GENANTE HERSTELLUNGSPROGRAMM ZEIGT UNSEREN KUNDEN UNSERE MÖGLICHKEITEN, WEIL ES IN DIESER PREISLISTE N° 6 NUR EIN TEIL DES HERSTELLUNGSPROGRAMMS DERGESTELLT IST.

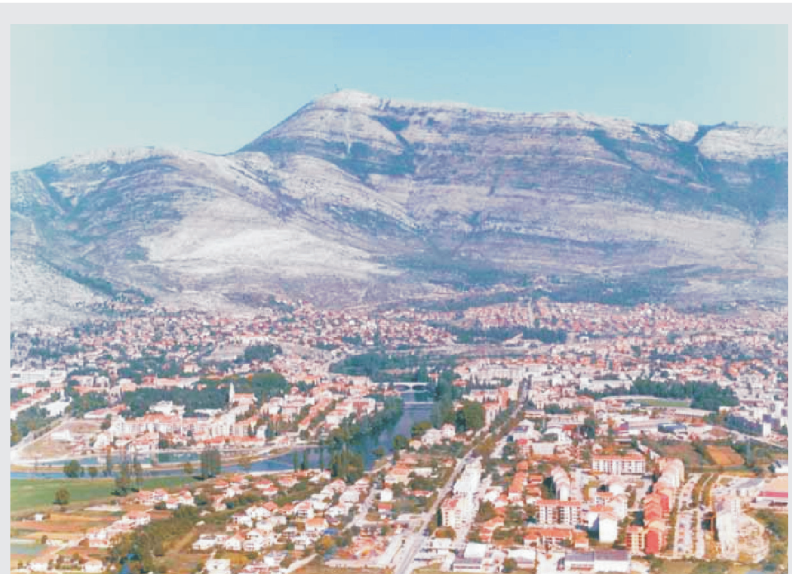

## SADRŽAJ - CONTENTS - INHALTSVERZEICHNIS



**SPIRALNE BURGJE  
TWIST DRILLS  
SPIRALBORER**



**NAVOJNI ALAT  
THREADING TOOLS  
GEWINDESCHNEIDWERKZEUGE**



**SPECIJALNI ALAT  
SPECIAL TOOLS  
SPECIALWERKZEUGE**



**ALAT SA TVRDIM METALOM  
CARBIDE TIPPED TOOLS  
HARTMETALLWERKZEUGE**





















**KOMPLETI REZNOG ALATA  
SETS OF THE CUTTING TOOL  
SCHNEIDWERKZEUGESÄTZE**

## OPIS SKRAĆENICA - DESCRIPTION - MERK

<b>HSS</b>	BRZOREZNI ČELIK Z GRUPE LEGIRANJA S 6-5-2	HIGH SPEED STEEL	SCHNELLARBEITSSTAHL
<b>Co 5%</b>	BRZOREZNI ČELIK IZ GRUPE LEGIRANJA S 6-5-2-5 - KOBALT 5 %	HIGH SPEED STEEL COBALT 5 %	SCHNELLARBEITSSTAHL MIT KOBALT 5 %
<b>Co 8%</b>	BRZOREZNI ČELIK IZ GRUPE LEGIRANJA S 2-10-1-8 - KOBALT 8 %	HIGH SPEED STEEL COBALT 8 %	SCHNELLARBEITSSTAHL MIT KOBALT 8 %
<b>HM</b>	TVRDI METAL	HARD METAL	HARTMETALL
<b>R</b>	DESNOREZNO	RIGHT	RECHTSSCHNEIDEND
<b>L</b>	LJEVOREZNO	LEFT	LINKSSCHNEIDEND
<b>W</b>	ZA RAD U MEKIM (M) MATERIJALIMA	WORK IN SOFT MATERIALS	BEARBEITUNG DER WEICHEN MATERIALE
<b>N</b>	ZA RAD U NORMALNIM (N) MATERIJALIMA	WORK IN NORMAL MATERIALS	BEARBEITUNG DER NORMALEN MATERIALE
<b>H</b>	ZA RAD U TVRDIM (T) MATERIJALIMA	WORK IN HARD MATERIALS	BEARBEITUNG DER HÄRTEN MATERIALE
<b>ROLLED</b>	VALJANE (TEHNOLOGIJA IZRADE)	ROLLED (EXECUTION)	GEROLLT (AUSFUHRUNG)
<b>MILLED</b>	GLODANE (TEHNOLOGIJA IZRADE)	GLODANE (EXECUTION)	GEFRÄST (AUSFUHRUNG)
<b>GROUND</b>	BRUŠENE (TEHNOLOGIJA IZRADE)	MILLED (EXECUTION)	GESCHLIFFEN (AUSFUHRUNG)
<b>BRIGHT</b>	SVIJETLO	BRIGHT (FINISH)	BLANK
<b>BLACK</b>	CRNO	BLACK (FINISH)	SCHWARZ
<b>GOLD</b>	ZLATNO	GOLD (FINISH)	GOLD
<b>A</b>	NORMALAN OBLIK VRHA SA ODBRUŠENIM JEZGROM	A - POINT ANGLE	A - FORM AUSGESPITZTE QUERSCHNEIDE
<b>C</b>	OBLIK VRHA SA KRSTASTO ODBRUŠENIM JEZGROM	C - POINT ANGLE	C - SPITZENFORM MIT KREUZANSCHLIFF
<b>MT N°</b>	VELIČINA KUPE	MORSETAPER	MORSEKONUS N°
<b>BRAD</b>	POSEBAN OBLIK VRHA	BRAD - POINT ANGLE	FORM ZENTRUMSPITZE
<b>A</b>	60° - ZABUŠIVAČI - OBLIK "A"	60° - CENTER DRILLS - TYPE "A"	60° - ZENTRIERBOHRER - FORM "A"
<b>R</b>	60° - ZABUŠIVAČI - OBLIK "R"	60° - CENTER DRILLS - TYPE "R"	60° - ZENTRIERBOHRER - FORM "R"
<b>B</b>	60°/120° - ZABUŠIVAČI - OBLIK "B"	60°/120° CENTER DRILLS - TYPE "B"	60°/120° - ZENTRIERBOHRER - FORM "B"
<b>FLAT</b>	FLEKA - ZARAVAN	TYPE - FLAT	FLÄCHE
<b>INTERRUPTED</b>	OBLIK - VADENI ZUB	TYPE - INTERRUPTED	FORM - AUSGESETZEN
<b>ROLLING THREAD</b>	OBLIK - UVALJIVAČ NAVOJA	TYPE - ROLLING THREAD	FORM - GEWINDEFORMER
<b>SPIRAL ENTRY</b>	OBLIK - KOŠA REZNA IVICA	TYPE - SPIRAL ENTRY	FORM - SCHELLANSCHNITT
<b>STRAIGHT</b>	OBLIK DRŠKE - VALJKASTA	TYPE - STRAIGHT SHANK	FORM - ZYLINDERSCHAFT
<b>WELDON</b>	OBLIK DRŠKE - SA FLEKOM	TYPE - WELDON SHANK	FORM - WELDON SCHAFT
<b>SCREWED</b>	OBLIK DRŠKE - SA NAVOJEM	TYPE - SCREWED SHANK	FORM - GEWINDE SCHAFT

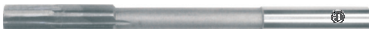

## SADRŽAJ - CONTENTS - INHALTSVERZEICHNIS

<p><b>SPIRALNE BURGIJE VALJKASTE</b>  <b>TWIST DRILLS STRAIGHT SHANK</b>  <b>SPIRALBORER MIT YZLINDERSCHAFT</b></p>		<p>2B - 36B</p>
<p><b>SPIRALNE BURGIJE KUPASTE</b>  <b>TWIST DRILLS MORSE TAPER SHANK</b>  <b>SPIRALBORER MIT MORSEKEGELSCHAFT</b></p>		<p>21B - 35B</p>
<p><b>ZABUŠIVAČI</b>  <b>COUNTERSINKS</b>  <b>ZENTRIERBOHRER</b></p>		<p>37B</p>
<p><b>TROČELJUSNE STEZNE GLAVE, SA KLJUČEM</b>  <b>THREE JAW DRILL CHUCKS, WITH KEY</b>  <b>DREIBACKEN - BOHRFUTER, MIT SCHLUSSEL</b></p>		<p>38B - 40B</p>
<p><b>RUČNI UREZNICI</b>  <b>HAND TAPS</b>  <b>HANDGEWINDEBOHRER</b></p>		<p>3N - 10N</p>
<p><b>MAŠINSKI UREZNICI</b>  <b>MACHINE TAPS</b>  <b>MACHINENGEWINDEBOHRER</b></p>		<p>11N - 22N</p>
<p><b>MAŠINSKI UREZNICI, CIJEVNI NAVOJ 1:16</b>  <b>MACHINE TAPS, PIPE THREAD (1:16)</b>  <b>MACHINENGEWINDEBOHRER ROHRGEWINDE (1:16)</b></p>		<p>23N</p>
<p><b>NAREZNICE OKRUGLE</b>  <b>ROUND DIES</b>  <b>RUNDE SCNEIDEISEN</b></p>		<p>24N - 28N</p>
<p><b>GLODALA</b>  <b>END MILLS</b>  <b>FRASER</b></p>		<p>3S - 12S</p>
<p><b>RAZVRTAČI</b>  <b>REAMERS</b>  <b>REIBAHLEN</b></p>		<p>13S - 20S</p>
<p><b>UPUŠTAČI</b>  <b>COUNTERBORERS</b>  <b>SENKER</b></p>		<p>21S - 35S</p>
<p><b>REDUCIR ČAURE</b>  <b>TAPER SLEEVES</b>  <b>VERLANGERUNGSHULSEN</b></p>		<p>36S - 37S</p>
<p><b>NOŽEVI</b>  <b>TOOL BITS</b>  <b>DREHLINGE</b></p>		<p>38S - 39S</p>
<p><b>STRUGARSKI NOŽEVI SA TM</b>  <b>CT - TOOL BITS</b>  <b>HM - DREHLINGE</b></p>		<p>2T - 4T</p>
<p><b>SPIRALNE BURGIJE SA TM</b>  <b>CARBIDE TIPPED TWIST DRILLS</b>  <b>HARTMETALL SPIRALBOHRER</b></p>		<p>5T - 11T</p>
<p><b>GLODALA SA TM</b>  <b>CT - END MILLS</b>  <b>HM - FRASER</b></p>		<p>12T - 13T</p>
<p><b>RAZVRTAČI SA TM</b>  <b>CT - REAMERS</b>  <b>HM - REIBAHLEN</b></p>		<p>14T - 19T</p>
<p><b>KOMPLETI REZNOG ALATA</b>  <b>SETS OF THE CUTTING TOOL</b>  <b>SCHNEIDWERKZEUGESATZE</b></p>		<p>1K - 6K</p>

**ZABILJEŠKE**

**NOTES**

**NOTE**

Lined area for notes.



N° 8



Bosnia and Herzegovina - REPUBLIC OF SRPSKA

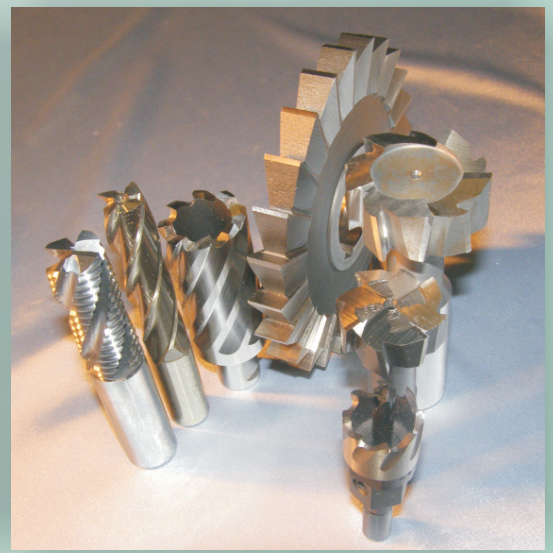
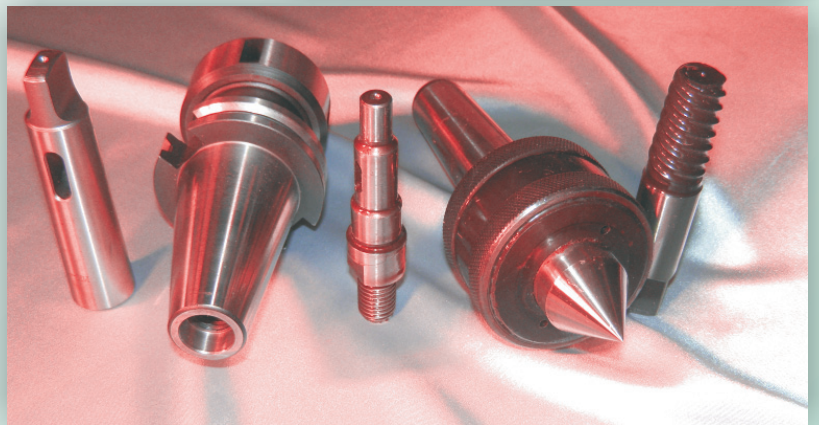

## STRUGARSKI NOŽEVI OD BRZOREZNOG ČELIKA

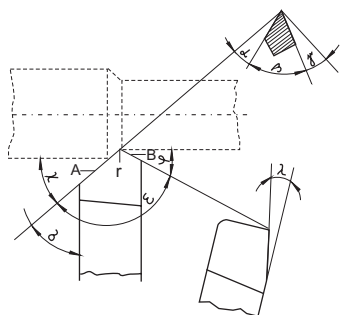

$\alpha$  - leđni ugao  
 $\beta$  - ugao klina  
 $\gamma$  - grudni ugao  
 $\epsilon$  - ugao vrha  
 $\chi$  - ugao podešavanja noža  
 $\lambda$  - ugao nagiba, negativan

r - glavna rezna ivica  
 A - radijus vrha

### VRSTE NOŽEVA

POLUPROIZVODI	STANDARDNI NOŽEVI	OSTALI NOŽEVI
<p>Toplotno obrađeni i obrušeni, služe najčešće, za obradu na automatima. Vrh noža oblikuje korisnik prema svojoj potrebi, a za tehničke uslove upućujemo na standard.</p>	<p>Potpuno oblikovani prema odgovarajućim standardima, služe za struganje i rendisanje na odgovarajućim mašinama. Normalno se izrađuju kao desni i lijevi na poseban zahtjev. Pored toga se izrađuju:</p> <ol style="list-style-type: none"> <li>1. oznaka F - u cjelini od brzoreznog čelika;</li> <li>2. oznaka G - sa reznim dijelom od brzoreznog čelika navarenim čeono na dršku od konstruktivnog čelika;</li> <li>3. oznaka P - sa pločicom od brzoreznog čelika.</li> </ol>	<p>Za posebne namjene raznih oblika i veličina. To su profilni noževi za obradu rukavaca radilice motora, noževi za obradu raznih profila i drugi.</p>

#### Preporučeni uglovi rezanja za rad noževima od brzoreznog čelika

Materijal	Čvrstoća (N/mm <sup>2</sup> ) Tvrdoća	Uglovi rezanja	
		Leđni ugao - $\alpha$	Grudni ugao - $\gamma$
Nelegirani konstruktivni čelik	do 850	8	14
Legirani konstruktivni čelik	700..850		
Nelegirani konstruktivni čelik	850..1000	8	10
Čelični liv			
Legirani konstruktivni čelik	850..1000		
Temper liv		8	6
Čelični liv	preko 700		
Legirani konstruktivni čelik	1000...1400		
<b>Nerđajući čelici</b>		5...8	15...20
Sivi liv	200...400 HB	8	0
Legirani sivi liv			
Bakar		8	18
Mesing	80...120 HB	8	0
Bronza			
Legura cinka		12	10
Aluminijum		12	30
Legure aluminijuma sa 11...13% Si		12	18
Aluminijski liv		12	14
Legure magnezijuma		8	6
Tvrda guma, ebonit I sl.		12	10
Izolacioni materijal, bakelit I sl.		12	14

## HSS TOOL BITS

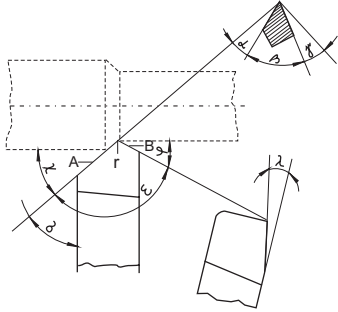

$\alpha$  - rake angle  
 $\beta$  - taper angle  
 $\gamma$  - face angle  
 $\epsilon$  - point angle  
 $\chi$  - tool bit setting angle  
 $\lambda$  - chamfer angle, negative

r - major cutting edge  
 A - point radius

## TOOL BIT TYPES

SEMIFINISHED PRODUCTS	STANDARD BITS	OTHER BIT TYPES
Heat treated and ground, used for work at automatic machines. Tool bit tip is formed by user according to his needs. For technical conditions refer to a standard.	Completely formed according to related standards, used for turning and shallow cuts on adequate machines. They are normally made as right and left on special request. Except these we make: 1. mark F - HSS complete; 2. mark G - HSS cutting part face welded on shank made of structural steel; 3. mark P - HSS tipped.	Different shapes and sizes for special use. Special profile bits for motor sleeves, bits for different profiles etc.

### Recommended cutting angles for HSS tool bits

Material	Toughness (N/mm <sup>2</sup> ) Hardness	Cutting angles	
		Thread angle - $\alpha$	Rake angle - $\gamma$
Unalloy structural steel	up to 850	8	14
Alloy structural steel	700..850		
Unalloy structural steel	850..1000	8	10
Cast steel			
Alloy structural steel	850..1000		
Malleable cast iron		8	6
Cast iron	over 700		
Alloy structural steel	1000...1400		
<b>Stainless steels</b>		5...8	15...20
Cast iron Alloy cast iron	200...400 HB	8	0
Copper		8	18
Brass	80...120 HB	8	0
Bronze			
Zinc alloy		12	10
Aluminum		12	30
Aluminum alloys with 11...13% Si		12	18
Cast aluminum		12	14
Magnesium alloys		8	6
Hard rubber, ebonit and similar		12	10
Isolation material, bakelite and similar		12	14



Preporučene brzine rezanja za rad noževima od brzoreznog čelika

Čelik noža	Pomak u mm	Nelegirani konstruktivni čelik								Legirani konstruktivni čelik						Čelični liv				Liveno gvožđe			
		500-600 N/mm <sup>2</sup>		600-700 N/mm <sup>2</sup>		700-850 N/mm <sup>2</sup>		850-1000 N/mm <sup>2</sup>		700-850 N/mm <sup>2</sup>		850-1000 N/mm <sup>2</sup>		1000-1400 N/mm <sup>2</sup>		300-500 N/mm <sup>2</sup>		500-700 N/mm <sup>2</sup>		do 200 Hb		200-500 Hb	
		Brzina rezanja Vm/min.								Brzina rezanja Vm/min.						Brzina rezanja Vm/min.							
		V60	V240	V60	V240	V60	V240	V60	V240	V60	V240	V60	V240	V60	V240	V60	V240	V60	V240	V60	V240	V60	V240
S 6 - 5 - 2 - 5	0,4	47	33	40	28	32	22	25	17	28	20	22	16	14	10	50	35	33	24	36	25	24	17
	0,8	36	25	30	21	24	17	18	13	20	15	16	11	10	7	37	26	25	17	24	17	17	12
	1,2	30	21	26	18	21	14	16	11	16	12	13	9			31	23	21	15	20	15	14	10
	1,6	26	18	22	16	17	12	14	10	14	10	11	8			28	20	18	13	18	14	12	9
	2,4	22	16	20	14	15	10	12	8	12	8					24	17	16	11	15	11	10	7
	3,2	20	14	17	12	13	9	10	7	10	6					21	14	14	10	12	9	8	6
S 6 - 5 - 2 - 10	0,4	51	35	43	30	34	24	27	18	30	21	24	17	16	11	54	38	35	25	38	27	26	18
	0,8	38	27	31	23	26	18	20	14	21	16	17	12	11	8	40	28	27	18	26	18	18	13
	1,2	33	23	27	20	22	15	17	12	18	13	14	10			34	24	23	16	22	16	16	11
	1,6	28	20	24	17	18	13	15	10	16	11	12	8			30	21	20	14	20	15	14	9
	2,4	24	18	21	15	16	11	13	9	13	9					26	18	17	12	16	12	11	8
	3,2	21	15	18	13	14	10	11	8	11	8					23	15	15	10	13	9	9	6

Recommended cutting speeds for HSS tool bits

Tool bit steel	Feed in mm	Unalloy structural steel								Alloy structural steel						Cast steel				Cast iron			
		500-600 N/mm <sup>2</sup>		600-700 N/mm <sup>2</sup>		700-850 N/mm <sup>2</sup>		850-1000 N/mm <sup>2</sup>		700-850 N/mm <sup>2</sup>		850-1000 N/mm <sup>2</sup>		1000-1400 N/mm <sup>2</sup>		300-500 N/mm <sup>2</sup>		500-700 N/mm <sup>2</sup>		do 200 Hb		200-500 Hb	
		Cutting speed Vm/min.								Cutting speed Vm/min.						Cutting speed Vm/min.							
		V60	V240	V60	V240	V60	V240	V60	V240	V60	V240	V60	V240	V60	V240	V60	V240	V60	V240	V60	V240	V60	V240
S 6 - 5 - 2 - 5	0,4	47	33	40	28	32	22	25	17	28	20	22	16	14	10	50	35	33	24	36	25	24	17
	0,8	36	25	30	21	24	17	18	13	20	15	16	11	10	7	37	26	25	17	24	17	17	12
	1,2	30	21	26	18	21	14	16	11	16	12	13	9			31	23	21	15	20	15	14	10
	1,6	26	18	22	16	17	12	14	10	14	10	11	8			28	20	18	13	18	14	12	9
	2,4	22	16	20	14	15	10	12	8	12	8					24	17	16	11	15	11	10	7
	3,2	20	14	17	12	13	9	10	7	10	6					21	14	14	10	12	9	8	6
S 6 - 5 - 2 - 10	0,4	51	35	43	30	34	24	27	18	30	21	24	17	16	11	54	38	35	25	38	27	26	18
	0,8	38	27	31	23	26	18	20	14	21	16	17	12	11	8	40	28	27	18	26	18	18	13
	1,2	33	23	27	20	22	15	17	12	18	13	14	10			34	24	23	16	22	16	16	11
	1,6	28	20	24	17	18	13	15	10	16	11	12	8			30	21	20	14	20	15	14	9
	2,4	24	18	21	15	16	11	13	9	13	9					26	18	17	12	16	12	11	8
	3,2	21	15	18	13	14	10	11	8	11	8					23	15	15	10	13	9	9	6

## GLODALA

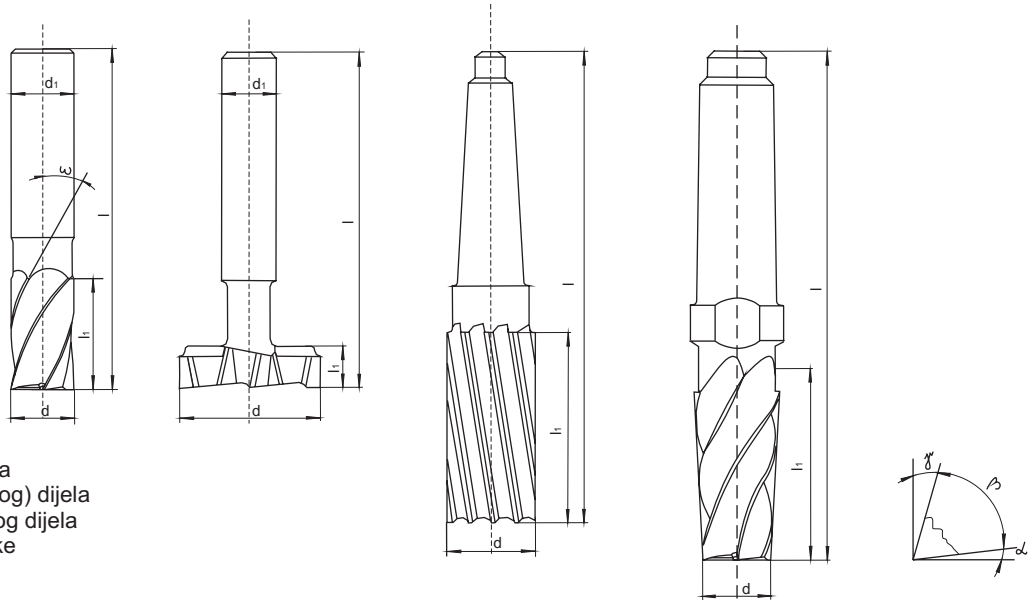

l - ukupna dužina glodala  
 l1 - dužina radnog (reznog) dijela  
 d - nazivni prečnik radnog dijela  
 d1 - nazivni prečnik drške  
 $\alpha$  - leđni ugao  
 $\beta$  - ugao klina  
 $\gamma$  - grudni ugao  
 $\omega$  - ugao zavojnice

## VRSTE GLODALA

### STANDARDNA GLODALA

### OSTALA GLODALA

Prema namjeni postoji više vrsta glodala: vretenasta, valjkasta, navojna, profilna i dr.

Normalno izrađujemo glodala: - tip N,  
 - desnorezna,  
 - sa desnom zavojnicom (kod glodala sa zavojnim žljebom),  
 - lijevorezna.

Na poseban zahtjev izrađujemo:

- tip T,  
 - tip M,  
 - sa lijevom zavojnicom (kod glodala sa zavojnim žljebom).

### Preporučeni režimi rezanja za glodala sa drškom

Materijal	Hladivo	Brzina v (m/min.)	s Pomak n Br. obr.	Prečnik glodala					
				5	8	12	16	25	40
				Pomak s (mm/min.) i srednji broj obrta n (obr./min.)					
Legirani čelik < 500 N/mm <sup>2</sup>	Emulzija	30...35	s n	40 2050	50 1300	65 860	70 650	75 415	100 260
Legirani čelik 500-700 N/mm <sup>2</sup>	Emulzija	25...30	s n	40 1750	50 1100	65 730	70 550	75 350	100 220
Legirani čelik 900-1100 N/mm <sup>2</sup>	Ulje	8...15	s n	20 730	30 460	40 310	50 230	60 145	75 92
Nerđajući čelik	Ulje	6...10	s n	20 480	25 320	30 210	40 160	50 100	60 63
Elektrolitski bakar	Emulzija	20...30	s n	50 1600	65 1000	80 650	100 500	120 320	150 200
Mesing krti	Emulzija	40...60	s n	60 3200	100 2000	150 1300	200 1000	300 640	400 400
Meka bronza	Ulje Emulzija	15...20	s n	50 11100	70 700	100 470	120 350	150 220	200 140
Aluminijum	Emulzija	60...80	s n	50 4500	80 2900	120 1850	200 1350	400 900	600 560

## MILLING CUTTERS

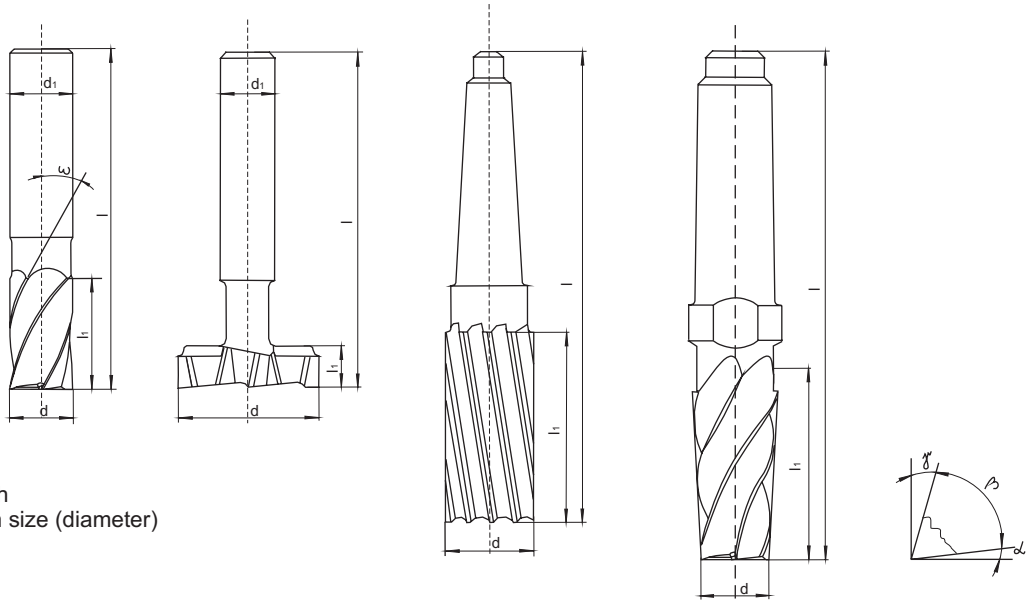

- l - overall length
- l1 - cutting section length
- d - actual cutting section size (diameter)
- d1 - actual shank size
- $\alpha$  - face angle
- $\beta$  - taper angle
- $\gamma$  - rake angle
- $\omega$  - helix angle

## TYPES OF MILLING CUTTERS

### STANDARD MILLING CUTTERS

Different types of milling cutters according to purpose: end mills, straight, thread, profile, etc.

Types of milling cutters in our regular production:

- type N,
- right hand,
- with right hand helix (milling cutters with helix flute),
- left hand.

### OTHER TYPES

At special request we manufacture:

- type T,
- type M,
- with left helix (milling cutters with helix flute).

Recommended cutting regimes for milling cutters with shank:

Material	Coolant	Speed $v$ (m/min.)	$s$ Feed $n$ No. of rev.	Milling cutter diameter					
				5	8	12	16	25	40
				Feed $s$ (mm/min.) & average no. of rev. $n$ (rpm)					
Alloy steel < 500 N/mm <sup>2</sup>	Emulsion	30...35	$s$ $n$	40 2050	50 1300	65 860	70 650	75 415	100 260
Alloy steel 500-700 N/mm <sup>2</sup>	Emulsion	25...30	$s$ $n$	40 1750	50 1100	65 730	70 550	75 350	100 220
Alloy steel 900-1100 N/mm <sup>2</sup>	Oil	8...15	$s$ $n$	20 730	30 460	40 310	50 230	60 145	75 92
Stainless steel	Oil	6...10	$s$ $n$	20 480	25 320	30 210	40 160	50 100	60 63
Copper electrolytic	Emulsion	20...30	$s$ $n$	50 1600	65 1000	80 650	100 500	120 320	150 200
Brass brittle	Emulsion	40...60	$s$ $n$	60 3200	100 2000	150 1300	200 1000	300 640	400 400
Bronze soft	Oil Emulsion	15...20	$s$ $n$	50 11100	70 700	100 470	120 350	150 220	200 140
Aluminum	Emulsion	60...80	$s$ $n$	50 4500	80 2900	120 1850	200 1350	400 900	600 560



## Preporučeni režimi rezanja za glodala sa drškom

Materijal	Hladivo	Brzina v (m/min.)	s Pomak n Br. obrtaja	Prečnik glodala					
				5	8	12	16	25	40
				Pomak s (mm/min.) i srednji broj obrtaja n (ob/min.)					
Nelegirani čelik < 500 N/mm <sup>2</sup>	Emulzija	30...35	s n	40 2050	50 1300	65 860	70 650	75 415	100 260
Nelegirani čelik 500-700 N/mm <sup>2</sup>	Emulzija	25...30	s n	40 1750	50 1100	65 730	70 550	75 350	100 200
Nelegirani čelik 700-900 N/mm <sup>2</sup>	Emulzija (ulje)	20...25	s n	30 1400	45 900	55 600	60 445	70 285	90 180
Legirani čelik 700-900 N/mm <sup>2</sup>	Emulzija (ulje)	15...20	s n	30 1100	45 700	65 470	60 350	70 220	90 140
Legirani čelik 700-1100 N/mm <sup>2</sup>	Ulje	8...15	s n	20 730	30 460	40 310	50 230	60 145	75 92
Nerđajući čelik	Ulje	6...10	s n	20 480	25 320	30 210	40 160	50 100	60 63
Čelični liv do ČL52	Emulzija	15...20	s n	40 1100	55 700	65 470	70 350	75 220	100 140
Čelični liv preko ČL52	Ulje	10...15	s n	30 800	45 500	55 335	60 250	70 160	90 100
Sivi liv do SL26	Vazduh	20...30	s n	45 1600	60 1000	75 650	85 500	100 320	150 200
Sivi liv preko SL26	Vazduh	10...20	s n	40 1000	55 600	65 400	70 300	75 190	100 120
Elektrolitski bakar	Emulzija	20...30	s n	50 1600	65 1000	80 650	100 500	120 320	150 200
Mesing krti	Emulzija	40...60	s n	60 3200	100 2000	150 1300	200 1000	300 640	400 400
Mesing žilavi	Emulzija	20...30	s n	50 1600	70 1000	100 650	120 500	150 320	200 200
Meka bronza	Ulje (emulzija)	15...20	s n	50 1100	70 700	100 470	120 350	150 220	200 140
Tvrda bronza	Emulzija	6...10	s n	20 480	30 320	50 210	75 160	100 100	120 63
Aluminijum	Emulzija	60...80	s n	50 4500	80 2900	120 1850	200 1350	400 900	600 560
Silumin Si > 12%	Emulzija	30...40	s n	50 2200	75 1400	100 930	150 700	250 450	400 280

Recommended cutting regimes for milling cutters with shank

Material	Coolant	Speed v (m/min.)	s Feed n No. of rev.	Milling cutter diameter					
				5	8	12	16	25	40
				Feed s (mm/min.) & average no. of rev. n (rpm)					
Unalloy steel < 500 N/mm <sup>2</sup>	Emulsion	30...35	s n	40 2050	50 1300	65 860	70 650	75 415	100 260
Unalloy steel 500-700 N/mm <sup>2</sup>	Emulsion	25...30	s n	40 1750	50 1100	65 730	70 550	75 350	100 200
Unalloy steel 700-900 N/mm <sup>2</sup>	Emulsion (oil)	20...25	s n	30 1400	45 900	55 600	60 445	70 285	90 180
Alloy steel 700-900 N/mm <sup>2</sup>	Emulsion (oil)	15...20	s n	30 1100	45 700	65 470	60 350	70 220	90 140
Alloy steel 700-1100 N/mm <sup>2</sup>	Oil	8...15	s n	20 730	30 460	40 310	50 230	60 145	75 92
Stainless steel	Oil	6...10	s n	20 480	25 320	30 210	40 160	50 100	60 63
Cast steel to 52	Emulsion	15...20	s n	40 1100	55 700	65 470	70 350	75 220	100 140
Cast steel over 52	Oil	10...15	s n	30 800	45 500	55 335	60 250	70 160	90 100
Cast iron to 26	Air	20...30	s n	45 1600	60 1000	75 650	85 500	100 320	150 200
Cast iron over 26	Air	10...20	s n	40 1000	55 600	65 400	70 300	75 190	100 120
Copper electrolytic	Emulsion	20...30	s n	50 1600	65 1000	80 650	100 500	120 320	150 200
Brass brittle	Emulsion	40...60	s n	60 3200	100 2000	150 1300	200 1000	300 640	400 400
Brass brittle	Emulsion	20...30	s n	50 1600	70 1000	100 650	120 500	150 320	200 200
Bronze soft	Oil (emulsion)	15...20	s n	50 1100	70 700	100 470	120 350	150 220	200 140
Bronze hard	Emulsion	6...10	s n	20 480	30 320	50 210	75 160	100 100	120 63
Aluminum	Emulsion	60...80	s n	50 4500	80 2900	120 1850	200 1350	400 900	600 560
Silumin Si > 12%	Emulsion	30...40	s n	50 2200	75 1400	100 930	150 700	250 450	400 280

## RAZVRTAČI

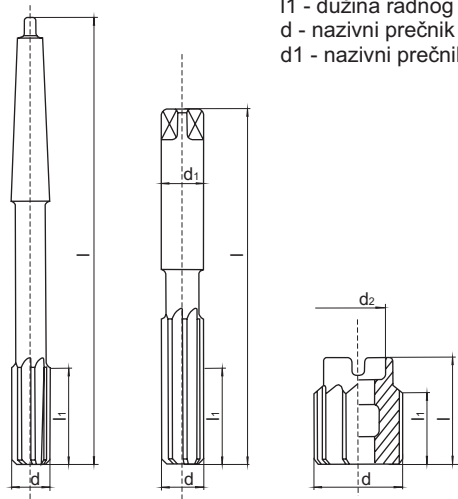

l - ukupna dužina razvrtača;  
 l1 - dužina radnog (reznog dijela);  
 d - nazivni prečnik radnog dijela;  
 d1 - nazivni prečnik vrata razvrtača;

## VRSTE RAZVRTAČA (PODJELA)

Prema upotrebi	Prema obliku rupe koju obrađujemo	Prema načinu stezanja (držci)	Prema pravcu zuba	Prema smjeru rezanja	Razvrtači sa zavojnim zubima
- ručni; - mašinski;	- valjkasti; - kupasti; - stepenasti; - kombinovani;	- sa valjkastom drškom; - sa MK drškom; - nasadni;	- sa pravim zubima; - sa zavojnim zubima;	- desnorezni; - lijevorezni;	- sa lijevom zavojnicom, lijevorezni (za prolazne rupe); - sa desnom zavojnicom, desnorezni (za neprolazne rupe).

## REAMERS

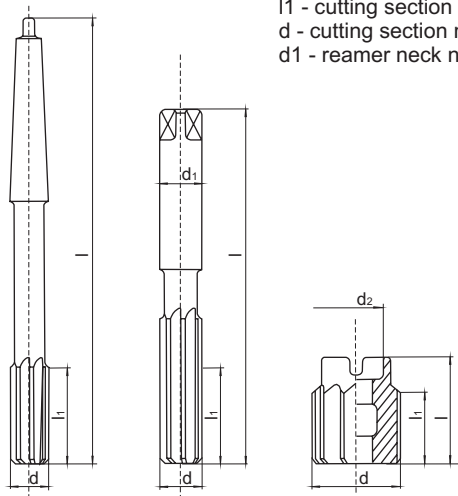

l - overall length;  
 l1 - cutting section length;  
 d - cutting section nominal diam.;  
 d1 - reamer neck nominal size ;

## REAMER TYPES

Acc. to usage	Acc. to hole shape it makes	Acc. to type of chucking (shank)	Acc. to flute direction	Acc. to rotation direction	Reamers with helical flute
- hand; - machine;	- straight; - taper; - step; - combined;	- straight shank; - Morse taper shank; - shell reamers;	- straight flute; - helical flute;	- right hand cut; - left hand cut;	- left hand helix, left hand cut (through holes); - right hand helix, right hand cut (blind holes).



## Preporučeni režimi razvrtanja

Materijal	Hladivo	Brzina v (m/min.)	s Pomak n Br. obr.	Prečnik razvrtača						
				2	5	8	12	16	25	40
				Pomak s (mm/min.) i srednji broj obrta n (obr./min.)						
Nelegirani čelik < 500 N/mm <sup>2</sup>	Emulzija	10...12	s n	0,05 1750	0,1 700	0,15 440	0,2 295	0,25 220	0,35 135	0,4 88
Nelegirani čelik 500-700 N/mm <sup>2</sup>	Emulzija	8...10	s n	0,05 1450	0,1 570	0,15 360	0,2 240	0,25 180	0,35 115	0,4 72
Nelegirani čelik 700-900 N/mm <sup>2</sup>	Ulje	6...8	s n	0,05 1130	0,1 445	0,15 280	0,2 185	0,25 140	0,35 90	0,4 56
Legirani čelik > 900 N/mm <sup>2</sup>	Ulje	4...6	s n	0,05 800	0,08 320	0,1 200	0,15 135	0,2 95	0,25 65	0,35 40
Nerđajući čelik	Ulje	3...5	s n	0,05 640	0,08 225	0,1 160	0,15 110	0,2 80	0,25 50	0,35 32
Sivi liv do 200 Hb	Petrolej	8...10	s n	0,1 1450	0,15 570	0,2 360	0,25 240	0,3 180	0,4 115	0,5 72
Sivi liv > 200 Hb	Petrolej	4...6	s n	0,05 800	0,1 320	0,15 200	0,2 135	0,25 95	0,35 65	0,4 40
Temper liv do 450 N/mm <sup>2</sup>	Ulje	8...10	s n	0,08 1450	0,15 570	0,2 360	0,25 240	0,3 80	0,4 115	0,5 72
Temper liv > 450 N/mm <sup>2</sup>	Ulje	6...8	s n	0,05 1130	0,1 445	0,15 280	0,2 185	0,25 140	0,35 90	0,4 56
Mesing krti	Emulzija	15...20	s n	0,08 2800	0,15 1120	0,2 780	0,25 470	0,3 340	0,4 225	0,5 140
Mesing žilav	Emulzija	8...15	s n	0,08 1850	0,15 730	0,2 445	0,25 300	0,3 230	0,4 145	0,5 92
Bronza	Ulje	6...8	s n	0,05 1130	0,1 445	0,15 280	0,2 185	0,25 140	0,35 90	0,4 56
Aluminijum	Emulzija	15...20	s n	0,08 2800	0,15 1115	0,2 780	0,25 470	0,3 340	0,4 225	0,5 140
Silumin Si < 12%	Emulzija	10...15	s n	0,08 2000	0,15 795	0,2 495	0,25 335	0,3 240	0,4 160	0,5 100
Silumin Si > 12%	Emulzija	8...10	s n	0,08 1450	0,15 570	0,2 360	0,25 240	0,3 180	0,4 115	0,5 72

## Dodatak po prečniku za razvrtanje (u mm)

Materijal	Prečnik rupe				
	do 2 mm	iznad 2 do 5 mm	iznad 5 do 10 mm	iznad 10 do 20 mm	iznad 20 mm
	Dodatak u mm				
Konstruktivni čelik	do 0,1	0,1...0,2	0,2	0,2	0,3...0,4
Nerđajući čelik	do 0,1	0,1...0,2	0,2	0,2	0,3
Sivi liv	do 0,1	0,1...0,2	0,2	0,2	0,3...0,5
Bronza	do 0,1	0,1...0,2	0,2	0,2	0,3
Mesing	do 0,1	0,1...0,2	0,2	0,2	0,3
Aluminijske legure	do 0,1	0,1...0,2	0,2...0,3	0,3...0,4	0,4...0,5
Bakar	do 0,1	0,1...0,2	0,2...0,3	0,3...0,4	0,4...0,5

Recommended reaming regimes

Material	Coolant	Speed $v$ (m/min.)	s Feed n No. of rev.	Reamer diameter						
				2	5	8	12	16	25	40
				Feed s (mm/min.) & average no. of rev. n (rpm)						
Unalloy steel < 500 N/mm <sup>2</sup>	Emulsion	10...12	s n	0,05 1750	0,1 700	0,15 440	0,2 295	0,25 220	0,35 135	0,4 88
Unalloy steel 500-700 N/mm <sup>2</sup>	Emulsion	8...10	s n	0,05 1450	0,1 570	0,15 360	0,2 240	0,25 180	0,35 115	0,4 72
Unalloy steel 700-900 N/mm <sup>2</sup>	Oil	6...8	s n	0,05 1130	0,1 445	0,15 280	0,2 185	0,25 140	0,35 90	0,4 56
Alloy steel > 900 N/mm <sup>2</sup>	Oil	4...6	s n	0,05 800	0,08 320	0,1 200	0,15 135	0,2 95	0,25 65	0,35 40
Stainless steel	Oil	3...5	s n	0,05 640	0,08 225	0,1 160	0,15 110	0,2 80	0,25 50	0,35 32
Cast iron to 200 Hb	Petroleum	8...10	s n	0,1 1450	0,15 570	0,2 360	0,25 240	0,3 180	0,4 115	0,5 72
Cast iron > 200 Hb	Petroleum	4...6	s n	0,05 800	0,1 320	0,15 200	0,2 135	0,25 95	0,35 65	0,4 40
Malleable cast iron to 450 N/mm <sup>2</sup>	Oil	8...10	s n	0,08 1450	0,15 570	0,2 360	0,25 240	0,3 80	0,4 115	0,5 72
Malleable cast iron > 450 N/mm <sup>2</sup>	Oil	6...8	s n	0,05 1130	0,1 445	0,15 280	0,2 185	0,25 140	0,35 90	0,4 56
Brass brittle	Emulsion	15...20	s n	0,08 2800	0,15 1120	0,2 780	0,25 470	0,3 340	0,4 225	0,5 140
Brass tough	Emulsion	8...15	s n	0,08 1850	0,15 730	0,2 445	0,25 300	0,3 230	0,4 145	0,5 92
Bronze	Oil	6...8	s n	0,05 1130	0,1 445	0,15 280	0,2 185	0,25 140	0,35 90	0,4 56
Aluminum	Emulsion	15...20	s n	0,08 2800	0,15 1115	0,2 780	0,25 470	0,3 340	0,4 225	0,5 140
Silumin Si < 12%	Emulsion	10...15	s n	0,08 2000	0,15 795	0,2 495	0,25 335	0,3 240	0,4 160	0,5 100
Silumin Si > 12%	Emulsion	8...10	s n	0,08 1450	0,15 570	0,2 360	0,25 240	0,3 180	0,4 115	0,5 72

Stock removal ( by diam.) (in mm)

Material	Hole diameter				
	to 2 mm	over 2 to 5 mm	over 5 to 10 mm	over 10 to 20 mm	over 20 mm
	Stock removal in mm				
Structural steel	to 0,1	0,1...0,2	0,2	0,2	0,3...0,4
Stainless steel	to 0,1	0,1...0,2	0,2	0,2	0,3
Cast iron	to 0,1	0,1...0,2	0,2	0,2	0,3...0,5
Bronze	do 0,1	0,1...0,2	0,2	0,2	0,3
Brass	do 0,1	0,1...0,2	0,2	0,2	0,3
Aluminium alloys	do 0,1	0,1...0,2	0,2...0,3	0,3...0,4	0,4...0,5
Copper	do 0,1	0,1...0,2	0,2...0,3	0,3...0,4	0,4...0,5

## UPUŠTAČI

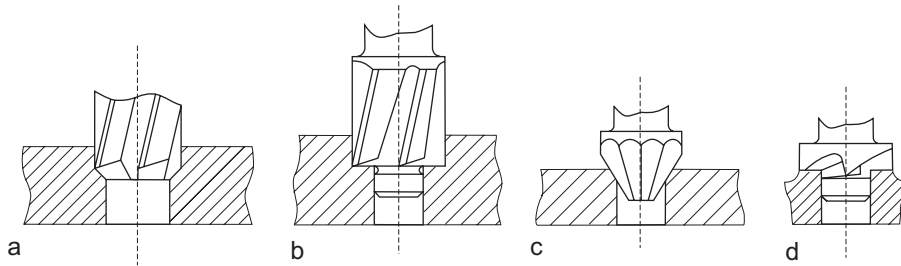

a, b, c, d - razni oblici (razne površine) upuštača prema obliku obrađivane površine (rupe);

## VRSTE UPUŠTAČA (PODJELA)

Prema obliku obrđivane površine	Prema načinu prihvatanja	Prema upotrebi
<ul style="list-style-type: none"> <li>- valjkasti (sl.a); služe za proširivanje rupe na veći prečnik;</li> <li>- čeoní (sl.b); služe za obradu upusta za glavu vijaka koja treba da bude upuštena;</li> <li>- kupasti (sl.c); služe za obradu kupastih upusta i gnijezda pod uglom od 60°, 90° ili 120°;</li> <li>- čeoní (sl.d); služe za poravnavanje površine;</li> </ul>	<ul style="list-style-type: none"> <li>- sa valjkastom drškom;</li> <li>- sa MK drškom;</li> </ul>	<ul style="list-style-type: none"> <li>- sa vođicom (promjenjiva ili čvrsta);</li> <li>- bez vođice.</li> </ul>

Preporuke za najmanje prečnike predhodno obrađene rupe i to za upuštače sa zavojnim zubima, DIN 343, (d<sub>2</sub>) i nasadne upuštače prema DIN 222, (d<sub>3</sub>).

Prečnik upuštača	Predhodna rupa	
	d <sub>1</sub>	d <sub>2</sub>
10	7	-
12	8,4	-
14	9,8	-
16	11,2	-
18	12,6	-
20	14	-
22	15	-
24	17	20
26	18	22
28	20	24
30	21	25

Prečnik upuštača	Predhodna rupa	
	d <sub>3</sub>	d <sub>4</sub>
32	22	27
34	24	29
36	25	31
38	27	33
40	28	34
42	29	36
44	31	38
46	32	40
48	34	42
50	35	43



## CORE DRILLS

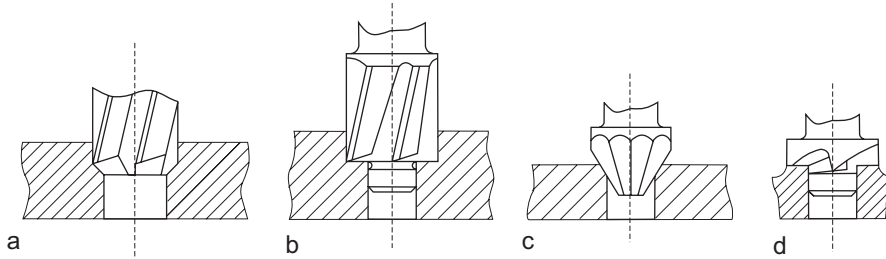

a, b, c, d - core drill different shapes (different surfaces) according to hole (surface) shape;

## CORE DRILL TYPES

<i>According to machined surface shape</i>	<i>According to chucking type</i>	<i>According to use</i>
<ul style="list-style-type: none"> <li>- straight (fig.a); for hole diameter enlarging ;</li> <li>- face core drills (fig.b); for screw head counterbore;</li> <li>- taper(fig.c); for sinking tapers (counterbores) and nests at an angle of 60°, 90° or 120°;</li> <li>- face core drills (fig.d); to even (hone) a surface;</li> </ul>	<ul style="list-style-type: none"> <li>- with straight shank;</li> <li>-with Morse taper shank;</li> </ul>	<ul style="list-style-type: none"> <li>- with leading part (changeable or fixed);</li> <li>- without leading part.</li> </ul>

Recommendations for the smallest diameters of previously machined hole and namely for core drills with helix land, DIN 343, ( $d_2$ ) and shell core drills according to DIN 222, ( $d_3$ ).

<i>Core drill diameter</i>	<i>Previous hole</i>	
	$d_1$	$d_2$
10	7	-
12	8,4	-
14	9,8	-
16	11,2	-
18	12,6	-
20	14	-
22	15	-
24	17	20
26	18	22
28	20	24
30	21	25

<i>Core drill diameter</i>	<i>Previous hole</i>	
	$d_3$	$d_4$
32	22	27
34	24	29
36	25	31
38	27	33
40	28	34
42	29	36
44	31	38
46	32	40
48	34	42
50	35	43



**FABRIKA SPECIJALNOG I OSTALOG ALATA**  
**SPECIAL TOOLS AND OTHER ACCESSOIRES FACTORY**  
**FABRIK VON SPEZIAL UND SONSTIGENWERKZEUGEN UND ZUBEHÖR**

phone: ++387 59/286-800 export: 280-972, import: 280-996, fax: 286-866  
 e-mail: [info@iat-tools.com](mailto:info@iat-tools.com) [www.iat-tools.com](http://www.iat-tools.com):

















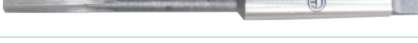
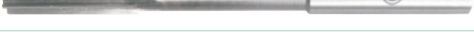

**PROIZVODNI PROGRAM:**

**PRODUCT LINE:**

**PRODUKTIONSPROGRAMM:**

GLODALA	END MILLS	FRÄSER
RAZVRTAČI	REAMERS	REIBAHLEN
SPECIJALNI RAZVRTAČI	SPECIAL PURPOSE REAMERS	SPEZIALREIBAHLEN
UPUŠTAČI	COUNTERBORES	SENKER
SPECIJALNI UPUŠTAČI	SPECIAL PURPOSE COUNTERBORES	SPEZIALSENKER
BURGIJE ZA LIM	METAL SHEET DRILLS	BLECHSCHÄLBOHRER
REDUCIR ČAURE	REDUCING SLEEVES	REDUZIERHÜLSEN
ČAURE	COLLETS	HÜLSEN
VODEĆE ČAURE	DRILL JIG BUSHINGS	FÜHRUNGSHULSEN
TRNOVI ZA STRUGANJE	LATHE MANDRELS	DREHDORNE
IZVIJAČI POLOMLJENIH VIJAKA	SCREW EXTRACTORS	SCHRAUBENAUSTREIBER
ALATI ZA SKIDANJE PUCNE	DEBURING TOOLS	ENTGRATWERKZEUGE
PROBIJAČI I SRODAN ALAT	PUNCHES & RELATED TOOLS	LOCHEISEN & ÄHNLICHE WERKZEUGE
ALATI ZA VIJČARE	FASTENER TOOLS	SCHRAUBENWERKZEUGE
PRIBOR ZA MAŠINE	MACHINE ACCESSORIES	MACSHINENZUBEHOR
NC ADAPTERI	NC TOOLS HOLDERS	NC WERKZEUGHALTER
NOSAČI NASADNIH GLODALA	ARBORS FOR SHELL END MILLS	AUFSTECKFRÄSDORNE
PRIBORI SPECIJALNE NAMJENE	SPECIAL PURPOSE ACCESSORIES	ZÜBEHOR FÜR SPEZIELLE ANWENDUNGEN
NARECKIVAČI I VALJČIĆI	KNURLING TOOLS & KNURLS	RÄNDELWERKZEUGE
PROFILNI VALJCI	PROFILE ROLLS	PROFILROLLEN
KRUNE ZA BUŠENJE LIMA	HOLE SAWS	LOCHSÄGE
STRUGARSKI NOŽEVI - POLUPROIZVOD	TOOL BITS - SEMIFINISHED	DREHMESSER - HALBZEUGE
STRUGARSKI NOŽEVI - STANDARDNI I SPECIJALNI	TOOL BITS - STANDARD & SPECIAL	DREHMESSER - STANDARD & SPEZIAL
NOŽEVI SPECIJALNE NAMJENE	SPECIAL PURPOSE TOOL BITS	DREHMESSER FÜR SPEZIELLE ANWENDUNGEN
NOŽEVI ZA TEKSTILNU INDUSTRIJU	BLADES FOR TEXTIL INDUSTRY	MESSER FÜR TEXTILINDUSTRIE











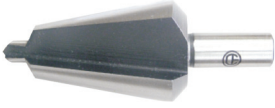



## SADRŽAJ - CONTENTS - INHALTSVERZEICHNIS

DIN	MATERIAL	SERIES		PAGE
327	HSS/HSS Co	SG01-SG09		3S
844	HSS/HSS Co	SG11-SG29		5S
845	HSS/HSS Co	SG41-SG43		7S
850	HSS/HSS Co	SG51-SG66		8S
851	HSS/HSS Co	SG71-SG79		10S
1833	HSS/HSS Co	SG81-SG88		11S
2328	HSS/HSS Co	SG91-SG92		12S
206	HSS/HSS Co	SR01-SR14		13S
208	HSS/HSS Co	SR11-SR14		15S
212	HSS/HSS Co	SR21-SR24		17S
311	HSS/HSS Co	SR37-SR38		18S
9	HSS/HSS Co	SR31-SR34		19S
219	HSS/HSS Co	SR91-SR94		20S
343	HSS/HSS Co	SU06-SU07		21S
373	HSS/HSS Co	SU01-SU04		22S
	HSS/HSS Co	SU61-SU62		24S
	HSS/HSS Co	SU35-SU42		25S
334	HSS/HSS Co	SU11-SU18		27S
335	HSS/HSS Co	SU21-SU28		29S

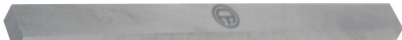





GRESKE I PROPUSTI MOGUĆI

ERRORS AND OMISSIONS EXCEPTED

## SADRŽAJ - CONTENTS - INHALTSVERZEICHNIS

DIN	MATERIAL	SERIES		PAGE
	HSS/HSS Co	SU51-SU52		33S
	HSS/HSS Co	SU55-SU56		
	HSS/HSS Co	SU63-SU64		34S
	HSS/HSS Co	SU65-SU66		
	HSS/HSS Co	SU67-SU68		
<b>222</b>	HSS/HSS Co	SU71-SU72		35S
<b>2185</b>		SP01		36S
<b>2187</b>		SP02		
<b>238</b>		SP05		37S
<b>4964</b>	HSS Co	SN21-SN26		38S
<b>4964</b>	HSS Co	SN31-SN36		
<b>4964</b>	HSS Co	SN01-SN07		39S
<b>4964</b>	HSS Co	SN11-SN18		
<b>842</b>	HSS/HSS Co	SG101-SG102		40S
<b>847</b>	HSS/HSS Co	SG103-SG104		41S

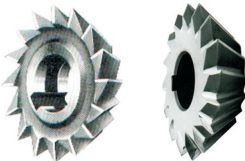

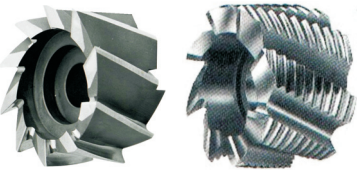
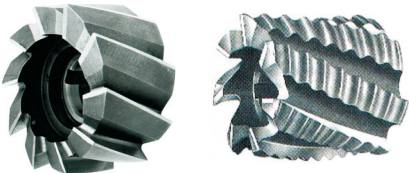

## SADRŽAJ - CONTENTS - INHALTSVERZEICHNIS

DIN	MATERIAL	SERIES		PAGE
855	HSS/HSS Co	SG105-SG106		41S
856	HSS/HSS Co	SG107-SG108		42S
844	HSS/HSS Co	SG109-SG110		
885	HSS/HSS Co	SG111-SG114		43S
1823	HSS/HSS Co	SG115-SG118		45S
1824	HSS/HSS Co	SG119-SG122		
1880	HSS/HSS Co	SG123-SG126		46S
	HSS/HSS Co	SG127-SG130		47S

GREŠKE I PROPUSTI MOGUĆI

ERRORS AND OMISSIONS EXCEPTED

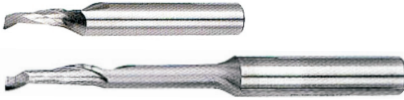
## SADRŽAJ - CONTENTS - INHALTSVERZEICHNIS

DIN	MATERIAL	SERIES		PAGE
1890	HSS/HSS Co	SG131-SG132		48S
	HSS/HSS Co	SG133-SG134		50S
6513	HSS/HSS Co	SG137-SG138		52S
	HSS/HSS Co	SG151-SG154		53S
	HSS/HSS Co	SG161-SG166		54S
	HSS/HSS-Co 5%	SG181-SG182		56S



**GLODALA ZA ŽLIJEB, VALJKASTA DRŠKA**

**SLOT CUTTERS, STRAIGHT SHANK**

**LONGLOCHFRÄSER, ZYLINDERSCHAFT**



Series					SG01	SG02	SG03	SG04	SG05	SG06	SG07	SG08	SG09	
	Material				HSS	HSS	HSS	Co 5%	Co 5%	Co 5%	Co 8%	Co 8%	Co 8%	
Type of shank				straight	weldon	screwed	straight	weldon	screwed	straight	weldon	screwed	screwed	
Form				B	D	H	B	D	H	B	D	H	H	
				price EUR										
				d <sub>1</sub>	l <sub>1</sub>	l <sub>2</sub>	d <sub>2</sub>	each	each	each	each	each	each	each
				mm	mm	mm	mm	each	each	each	each	each	each	each
00400	4	51	7	6	<b>6,877</b>	7,560	7,560	8,938	9,834	9,834	10,315	11,346	11,346	
00450	4,5	51	7	6	8,288	9,117	9,117	10,774	11,850	11,850	12,432	13,675	13,675	
00500	5	52	8	6	<b>6,877</b>	7,560	7,560	8,938	9,834	9,834	10,315	11,346	11,346	
00550	5,5	52	8	6	8,176	8,994	8,994	10,629	11,693	11,693	12,264	13,496	13,496	
00600	6	52	8	6	<b>6,832</b>	7,515	7,515	8,882	9,766	9,766	10,248	11,278	11,278	
00650	6,5	60	10	10	10,685	11,749	11,749	13,888	15,277	15,277	16,027	17,629	17,629	
00700	7	60	10	10	9,789	10,763	10,763	12,723	14,000	14,000	14,683	16,150	16,150	
00750	7,5	60	10	10	10,685	11,749	11,749	13,888	15,277	15,277	16,027	17,629	17,629	
00800	8	61	11	10	<b>8,893</b>	9,778	9,778	11,558	12,712	12,712	13,339	14,672	14,672	
00850	8,5	61	11	10	10,976	12,074	12,074	14,269	15,691	15,691	16,464	18,110	18,110	
00900	9	61	11	10	10,013	11,010	11,010	13,014	14,314	14,314	15,019	16,520	16,520	
00950	9,5	61	11	10	10,976	12,074	12,074	14,269	15,691	15,691	16,464	18,110	18,110	
01000	10	63	13	10	<b>9,117</b>	10,024	10,024	11,850	13,037	13,037	13,675	15,042	15,042	
01050	10,5	70	13	12	18,560	20,416	20,416	24,128	26,544	26,544	27,840	30,624	30,624	
01100	11	70	13	12	16,640	18,304	18,304	21,632	23,792	23,792	24,960	27,456	27,456	
01200	12	73	16	12	<b>15,360</b>	16,896	16,896	19,968	21,968	21,968	23,040	25,344	25,344	
01250	12,5	73	16	12	22,400	24,640	24,640	29,120	32,032	32,032	33,600	36,960	36,960	
01300	13	73	16	12	21,120	23,232	23,232	27,456	30,208	30,208	31,680	34,848	34,848	
01400	14	73	16	12	18,560	20,416	20,416	24,128	26,544	26,544	27,840	30,624	30,624	
01500	15	73	16	12	21,760	23,936	23,936	28,288	31,120	31,120	32,640	35,904	35,904	
01600	16	79	19	16	21,760	23,936	23,936	28,288	31,120	31,120	32,640	35,904	35,904	
01700	17	79	19	16	29,440	32,384	32,384	38,272	42,096	42,096	44,160	48,576	48,576	
01800	18	79	19	16	24,960	27,456	27,456	32,448	35,696	35,696	37,440	41,184	41,184	
01900	19	88	22	16	34,560	38,016	38,016	44,928	49,424	49,424	51,840	57,024	57,024	
02000	20	88	22	20	28,800	31,680	31,680	37,440	41,184	41,184	43,200	47,520	47,520	
02100	21	88	22	20	48,800	53,680	53,680	63,440	69,780	69,780	73,200	80,520	80,520	
02200	22	88	22	20	40,800	44,880	44,880	53,040	58,340	58,340	61,200	67,320	67,320	
02300	23	88	22	20	59,200	65,120	65,120	76,960	84,660	84,660	88,800	97,680	97,680	
02400	24	102	26	25	49,600	54,560	54,560	64,480	70,920	70,920	74,400	81,840	81,840	

\*Posebno označene cijene ( **bold** ) odnose se na robu koju imamo na lageru. Za ostali asortiman rabate i rokove isporuke dajemo na osnovu upita.

\*Prices given in **bold** figures refer to products on stock. Discount and delivery terms for other product assortment are given at request.

\*Die separat gekennzeichneten Prices ( **bold** ) beziehen sich auf die Ware, die auf Lager liegt. Die Rabatte und Lieferzeiten für das restliche Sortiment geben wir auf Anfrage bekannt.

Series	SG01 SG02 SG03 SG04 SG05 SG06 SG07 SG08 SG09												
	Material	HSS	HSS	HSS	Co 5%	Co 5%	Co 5%	Co 8%	Co 8%	Co 8%			
	Type of shank	straight	weldon	screwed	straight	weldon	screwed	straight	weldon	screwed			
	Form	B	D	H	B	D	H	B	D	H			
	d <sub>1</sub>	l <sub>1</sub>	l <sub>2</sub>	d <sub>2</sub>	price EUR								
	mm	mm	mm	mm	each	each	each	each	each	each	each	each	each
02400	25	102	26	25	49,600	54,560	54,560	64,480	70,920	70,920	74,400	81,840	81,840
02600	26	102	26	25	67,200	73,920	73,920	87,360	96,100	96,100	100,800	110,880	110,880
02700	27	102	26	25	72,800	80,080	80,080	94,640	104,100	104,100	109,200	120,120	120,120
02800	28	102	26	25	60,800	66,880	66,880	79,040	86,940	86,940	91,200	100,320	100,320
02900	29	102	26	25	90,400	99,440	99,440	117,520	129,280	129,280	135,600	149,160	149,160
03000	30	102	26	25	75,200	82,720	82,720	97,760	107,540	107,540	112,800	124,080	124,080
03200	32	112	32	32	75,200	82,720	82,720	97,760	107,540	107,540	112,800	124,080	124,080
03400	34	112	32	32	115,200	126,720	126,720	149,760	164,740	164,740	172,800	190,080	190,080
03500	35	112	32	32	106,400	117,040	117,040	138,320	152,160	152,160	159,600	175,560	175,560
03600	36	112	32	32	96,000	105,600	105,600	124,800	137,280	137,280	144,000	158,400	158,400
03800	38	130	38	40	132,000	145,200	145,200	171,600	188,760	188,760	198,000	217,800	217,800
04000	40	130	38	40	120,000	132,000	132,000	156,000	171,600	171,600	180,000	198,000	198,000
04500	45	130	38	40	152,000	167,200	167,200	197,600	217,360	217,360	228,000	250,800	250,800
05000	50	147	45	50	195,200	214,720	214,720	253,760	279,140	279,140	292,800	322,080	322,080

\*Posebno označene cijene ( **bold** ) odnose se na robu koju imamo na lageru. Za ostali asortiman rabate i rokove isporuke dajemo na osnovu upita.

\*Prices given in **bold** figures refer to products on stock. Discount and delivery terms for other product assortment are given at request.

\*Die separat gekennzeichneten Prices ( **bold** ) beziehen sich auf die Ware, die auf Lager liegt. Die Rabatte und Lieferzeiten für das restliche Sortiment geben wir auf Anfrage bekannt.

**GLODALA VREtenASTA, VALJKASTA DRŠKA**

**END MILLS, STRAIGHT SHANK**

**SCHAFTFRÄSER, ZYLINDERSCHAFT**

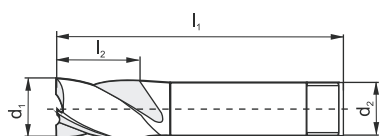

Series	SG11 SG12 SG13 SG14 SG15 SG16 SG17 SG18 SG19														
	Material		HSS	HSS	HSS	Co 5%	Co 5%	Co 5%	Co 8%	Co 8%	Co 8%				
	Type of shank		straight	weldon	screwed	straight	weldon	screwed	straight	weldon	screwed				
	Form		A	B	D	A	B	D	A	B	D				
	d <sub>1</sub>	l <sub>1</sub>	l <sub>2</sub>	d <sub>2</sub>	Z	price EUR					price EUR				
	mm	mm	mm	mm		each	each	each	each	each	each	each	each	each	each
00400	4	55	11	6	4	<b>8,736</b>	9,610	9,610	11,357	12,488	12,488	13,104	14,414	14,414	
00450	4,5	55	11	6	4	10,864	11,950	11,950	14,123	15,534	15,534	16,296	17,931	17,931	
00500	5	57	13	6	4	<b>9,072</b>	9,979	9,979	11,794	12,970	12,970	13,608	14,974	14,974	
00550	5,5	57	13	6	4	11,200	12,320	12,320	14,560	16,016	16,016	16,800	18,480	18,480	
00600	6	57	13	6	4	<b>9,341</b>	10,270	10,270	12,141	13,362	13,362	14,011	15,411	15,411	
00650	6,5	66	16	10	4	12,320	13,552	13,552	16,016	17,618	17,618	18,480	20,328	20,328	
00700	7	66	16	10	4	11,200	12,320	12,320	14,560	16,016	16,016	16,800	18,480	18,480	
00750	7,5	66	16	10	4	12,320	13,552	13,552	16,016	17,618	17,618	18,480	20,328	20,328	
00800	8	69	19	10	4	<b>10,192</b>	11,211	11,211	13,250	14,571	14,571	15,288	16,822	16,822	
00850	8,5	69	19	10	4	13,440	14,784	14,784	17,472	19,219	19,219	20,160	22,176	22,176	
00900	9	69	19	10	4	12,320	13,552	13,552	16,016	17,618	17,618	18,480	20,328	20,328	
00950	9,5	69	19	10	4	13,440	14,784	14,784	17,472	19,219	19,219	20,160	22,176	22,176	
01000	10	72	22	10	4	<b>11,088</b>	12,197	12,197	14,414	15,859	15,859	16,632	18,301	18,301	
01100	11	79	22	12	4	14,000	15,400	15,400	18,200	20,026	20,026	21,000	23,106	23,106	
01200	12	83	26	12	4	<b>12,589</b>	13,843	13,843	16,363	17,998	17,998	18,883	20,776	20,776	
01300	13	83	26	12	4	22,400	24,640	24,640	29,120	32,032	32,032	33,600	36,960	36,960	
01400	14	83	26	12	4	<b>20,384</b>	22,416	22,416	26,496	29,152	29,152	30,576	33,632	33,632	
01500	15	83	26	12	4	21,184	23,296	23,296	27,536	30,288	30,288	31,776	34,960	34,960	
01600	16	92	32	16	4	<b>21,184</b>	23,296	23,296	27,536	30,288	30,288	31,776	34,960	34,960	
01700	17	92	32	16	4	33,184	36,496	36,496	43,136	47,456	47,456	49,776	54,752	54,752	
01800	18	92	32	16	4	27,584	30,336	30,336	35,856	39,440	39,440	41,376	45,520	45,520	
01900	19	92	32	16	4	40,800	44,880	44,880	53,040	58,352	58,352	61,200	67,328	67,328	
02000	20	104	38	20	4	<b>33,984</b>	37,376	37,376	44,176	48,592	48,592	50,976	56,080	56,080	
02200	22	104	38	20	6	43,200	47,520	47,520	56,160	61,776	61,776	64,800	71,280	71,280	
02400	24	121	45	25	6	50,400	55,440	55,440	65,520	72,080	72,080	75,600	83,168	83,168	
02500	25	121	45	25	6	50,400	55,440	55,440	65,520	72,080	72,080	75,600	83,168	83,168	
02600	26	121	45	25	6	55,200	60,720	60,720	71,760	78,944	78,944	82,800	91,088	91,088	
02800	28	121	45	25	6	56,800	62,480	62,480	73,840	81,232	81,232	85,200	93,728	93,728	
03000	30	121	45	25	6	70,400	77,440	77,440	91,520	100,672	100,672	105,600	116,160	116,160	
03200	32	133	53	32	6	70,400	77,440	77,440	91,520	100,672	100,672	105,600	116,160	116,160	

\*Posebno označene cijene ( **bold** ) odnose se na robu koju imamo na lageru. Za ostali asortiman rabate i rokove isporuke dajemo na osnovu upita.

\*Prices given in **bold** figures refer to products on stock. Discount and delivery terms for other product assortment are given at request.

\*Die separat gekennzeichneten Prices ( **bold** ) beziehen sich auf die Ware, die auf Lager liegt. Die Rabatte und Lieferzeiten für das restliche Sortiment geben wir auf Anfrage bekannt.

**GLODALA VREtenASTA, VALJKASTA DRŠKA**

**END MILLS, STRAIGHT SHANK**

**SCHAFTFRÄSER, ZYLINDERSCHAFT**

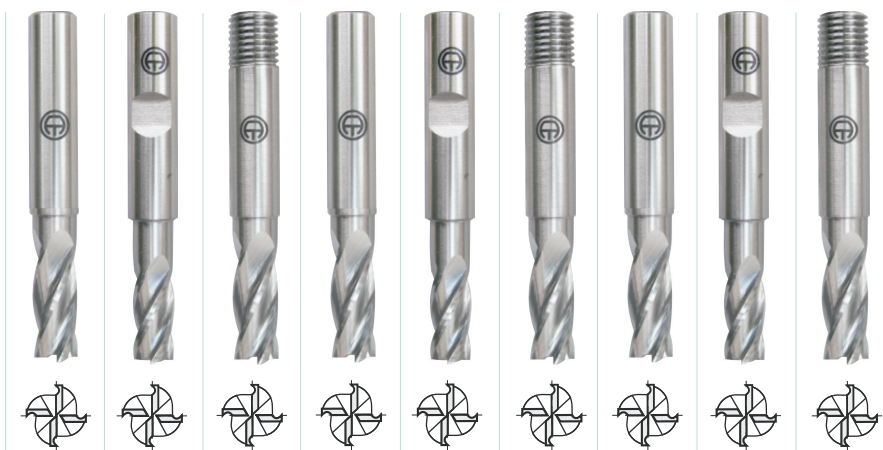
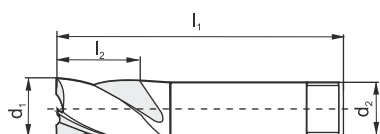

Series						SG21	SG22	SG23	SG24	SG25	SG26	SG27	SG28	SG29
Material						HSS	HSS	HSS	Co 5%	Co 5%	Co 5%	Co 8%	Co 8%	Co 8%
Type of shank						straight	weldon	screwed	straight	weldon	screwed	straight	weldon	screwed
Form						A	B	D	A	B	D	A	B	D
	d <sub>1</sub>	l <sub>1</sub>	l <sub>2</sub>	d <sub>2</sub>	Z	price EUR								
	mm	mm	mm	mm		each	each	each	each	each	each	each	each	each
00400	4	55	11	6	4	9,610	10,573	10,573	12,488	13,742	13,742	14,414	15,859	15,859
00450	4,5	55	11	6	4	11,950	13,149	13,115	15,534	17,091	17,091	185,931	19,723	19,723
00500	5	57	13	6	4	9,979	10,976	10,976	12,970	14,269	14,269	14,974	16,464	16,464
00550	5,5	57	13	6	4	12,320	13,552	13,552	16,016	17,618	17,618	18,480	20,328	20,328
00600	6	57	13	6	4	10,270	11,301	11,301	13,362	14,694	14,694	15,411	16,957	16,957
00650	6,5	66	16	10	4	13,552	14,907	14,907	17,618	19,376	19,376	20,328	22,366	22,366
00700	7	66	16	10	4	12,320	13,552	13,552	16,016	17,618	17,618	18,480	20,328	20,328
00750	7,5	66	16	10	4	13,552	14,907	14,907	17,618	19,376	19,376	20,328	22,366	22,366
00800	8	69	19	10	4	11,211	12,331	12,331	14,571	16,027	16,027	16,822	18,502	18,502
00850	8,5	69	19	10	4	14,784	16,262	16,262	19,219	21,146	21,146	22,176	24,394	24,394
00900	9	69	19	10	4	13,552	14,907	14,907	17,618	19,376	19,376	20,328	22,366	22,366
00950	9,5	69	19	10	4	14,784	16,262	16,262	19,219	21,146	21,146	22,176	24,394	24,394
01000	10	72	22	10	4	12,197	13,418	13,418	15,859	17,438	17,438	18,301	20,126	20,126
01100	11	79	22	12	4	15,400	16,946	16,946	20,026	22,019	22,019	23,106	25,413	25,413
01200	12	83	26	12	4	13,843	15,232	15,232	17,998	19,802	19,802	20,776	22,848	22,848
01300	13	83	26	12	4	24,640	27,104	27,104	32,032	35,232	35,232	36,960	40,656	40,656
01400	14	83	26	12	4	22,416	24,672	24,672	29,152	32,064	32,064	33,632	36,992	36,992
01500	15	83	26	12	4	23,296	25,632	25,632	30,288	33,328	33,328	34,960	38,448	38,448
01600	16	92	32	16	4	23,296	25,632	25,632	30,288	33,328	33,328	34,960	38,448	38,448
01700	17	92	32	16	4	36,496	40,160	40,160	47,456	52,192	52,192	54,752	60,224	60,224
01800	18	92	32	16	4	30,336	33,376	33,376	39,440	43,392	43,392	45,504	50,064	50,064
01900	19	92	32	16	4	44,880	49,376	49,376	58,352	64,176	64,176	67,328	74,048	74,048
02000	20	104	38	20	4	37,376	41,120	41,120	48,592	53,456	53,456	56,080	61,680	61,680
02200	22	104	38	20	6	47,520	52,272	52,272	61,776	67,952	67,952	71,280	78,416	78,416
02400	24	121	45	25	6	55,440	60,992	60,992	72,080	79,280	79,280	83,168	91,472	91,472
02500	25	121	45	25	6	55,440	60,992	60,992	72,080	79,280	79,280	83,168	91,472	91,472
02600	26	121	45	25	6	60,720	66,800	66,800	78,944	86,832	86,832	91,088	100,192	100,192
02800	28	121	45	25	6	62,480	68,736	68,736	81,232	89,344	89,344	93,728	103,088	103,088
03000	30	121	45	25	6	77,440	85,184	85,184	100,672	110,736	110,736	116,160	127,776	127,776
03200	32	133	53	32	6	77,440	85,184	85,184	100,672	110,736	110,736	116,160	127,776	127,776

\*Posebno označene cijene ( **bold** ) odnose se na robu koju imamo na lageru. Za ostali asortiman rabate i rokove isporuke dajemo na osnovu upita.

\*Prices given in **bold** figures refer to products on stock. Discount and delivery terms for other product assortment are given at request.

\*Die separat gekennzeichneten Prices ( **bold** ) beziehen sich auf die Ware, die auf Lager liegt. Die Rabatte und Lieferzeiten für das restliche Sortiment geben wir auf Anfrage bekannt.

GLODALA VRETENASTA, KUPASTA DRŠKA

END MILLS, MORSE TAPER SHANK

SCHAFTFRÄSER, MORSEKEGEL

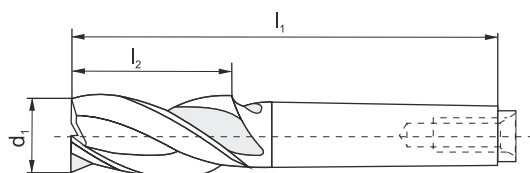

Series	Material					SG41	SG42	SG43
	Type					HSS	Co 5%	Co 8%
	d <sub>1</sub>	l <sub>1</sub>	l <sub>2</sub>	MT	M	N	N	N
	mm	mm	mm			price EUR		
						each	each	each
00600	6	89	22	1	M6	25,184	32,736	37,776
00700	7	89	22	1	M6	25,184	32,736	37,776
00800	8	96	25	1	M6	25,184	32,736	37,776
00900	9	96	25	1	M6	28,000	36,400	42,000
01000	10	92	22	1	M6	24,384	31,696	36,576
01100	11	92	22	1	M6	28,800	37,440	43,200
01200	12	96	26	1	M6	25,984	33,776	38,976
01300	13	96	26	1	M6	31,200	40,560	46,800
01400	14	111	26	2	M10	28,384	36,896	42,576
01500	15	111	26	2	M10	31,584	41,056	47,376
01600	16	117	32	2	M10	31,584	41,056	47,376
01700	17	117	32	2	M10	42,400	55,120	63,600
01800	18	117	32	2	M10	35,200	45,760	52,800
01900	19	117	32	2	M10	48,800	63,440	73,200
02000	20	123	38	2	M10	40,800	53,040	61,200
02100	21	123	38	2	M10	58,400	75,920	87,600
02200	22	123	38	2	M10	48,800	63,440	73,200
02300	23	123	38	2	M10	70,400	91,520	105,600
02400	24	147	45	3	M12	58,400	75,920	87,600
02500	25	147	45	3	M12	58,400	75,920	87,600
02600	26	147	45	3	M12	75,200	97,760	112,800
02700	27	147	45	3	M12	81,600	106,080	122,400
02800	28	147	45	3	M12	68,000	88,400	102,000
02900	29	147	45	3	M12	126,400	164,320	189,600
03000	30	147	45	3	M12	105,600	137,280	158,400
04000	40	188	63	4	M16	112,640	146,432	168,960
05000	50	233	75	5	M20	211,200	274,560	316,800

\*Posebno označene cijene ( **bold** ) odnose se na robu koju imamo na lageru. Za ostali asortiman rabate i rokove isporuke dajemo na osnovu upita.

\*Prices given in **bold** figures refer to products on stock. Discount and delivery terms for other product assortment are given at request.

\*Die separat gekennzeichneten Prices ( **bold** ) beziehen sich auf die Ware, die auf Lager liegt. Die Rabatte und Lieferzeiten für das restliche Sortiment geben wir auf Anfrage bekannt.



**GLODALA ZA ŽLIJEB ZA SEGMENTNI KLIN, VALJKASTA DRŠKA**

**WOODRUFF KEYSEAT CUTTERS, STRAIGHT SHANK**

**SCHAFTFRÄSER, ZYLINDERSCHAFT**

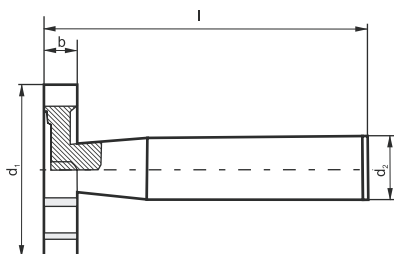

Series						SG51	SG52	SG53	SG54	SG55	SG56
	Material					HSS	Co 5%	HSS	Co 5%	HSS	Co 5%
Type of shank					straight	straight	weldon	weldon	screwed	screwed	
					price EUR						
	d <sub>1</sub>	l	b	d <sub>2</sub>	Z						
	mm	mm	mm	mm	A	each	each	each	each	each	each
045010	4,5	50	1	6	10	17,760	23,088	18,648	24,240	18,648	24,240
075015	7,5	50	1,5	6	10	19,200	24,960	20,160	26,208	20,160	26,208
075020	7,5	50	2	6	10	19,200	24,960	20,160	26,208	20,160	26,208
105020	10,5	50	2	6	10	21,600	28,080	22,680	29,484	22,680	29,484
105025	10,5	50	2,5	6	10	21,600	28,080	22,680	29,484	22,680	29,484
105030	10,5	50	3	6	10	21,600	28,080	22,680	29,484	22,680	29,484
135030	13,5	56	3	10	10	24,000	31,200	25,200	32,760	25,200	32,760
135040	13,5	56	4	10	10	24,000	31,200	25,200	32,760	25,200	32,760
165030	16,5	56	3	10	10	25,920	33,696	27,216	35,376	27,216	35,376
165040	16,5	56	4	10	10	25,920	33,696	27,216	35,376	27,216	35,376
165050	16,5	56	5	10	10	25,920	33,696	27,216	35,376	27,216	35,376
195040	19,5	63	4	10	10	37,760	49,088	39,648	51,536	39,648	51,536
195050	19,5	63	5	10	12	37,760	49,088	39,648	51,536	39,648	51,536
195060	19,5	63	6	10	12	37,760	49,088	39,648	51,536	39,648	51,536
225050	22,5	63	5	10	12	44,160	57,408	46,368	60,272	46,368	60,272
225060	22,5	63	6	10	12	44,160	57,408	46,368	60,272	46,368	60,272
225080	22,5	63	8	10	12	44,160	57,408	46,368	60,272	46,368	60,272
255060	25,5	63	6	10	14	56,960	74,048	59,808	77,744	59,808	77,744
285060	28,5	63	6	10	16	64,000	83,200	67,200	87,360	67,200	87,360
285080	28,5	63	8	10	16	64,000	83,200	67,200	87,360	67,200	87,360
285100	28,5	71	10	12	16	64,000	83,200	67,200	87,360	67,200	87,360
325070	32,5	71	7	12	18	71,040	92,352	74,592	96,976	74,592	96,976
325080	32,5	71	8	12	18	71,040	92,352	74,592	96,976	74,592	96,976
325100	32,5	71	10	12	18	71,040	92,352	74,592	96,976	74,592	96,976
455100	45,5	71	10	12	22	138,240	179,712	145,152	188,704	145,152	188,704

\*Posebno označene cijene ( **bold** ) odnose se na robu koju imamo na lageru. Za ostali asortiman rabate i rokove isporuke dajemo na osnovu upita.

\*Prices given in **bold** figures refer to products on stock. Discount and delivery terms for other product assortment are given at request.

\*Die separat gekennzeichneten Prices ( **bold** ) beziehen sich auf die Ware, die auf Lager liegt. Die Rabatte und Lieferzeiten für das restliche Sortiment geben wir auf Anfrage bekannt.



GLODALA ZA ŽLIJEB ZA SEGMENTNI KLIN, VALJKASTA DRŠKA

WOODRUFF KEYSEAT CUTTERS, STRAIGHT SHANK

SCHAFTFRÄSER, ZYLINDERSCHAFT

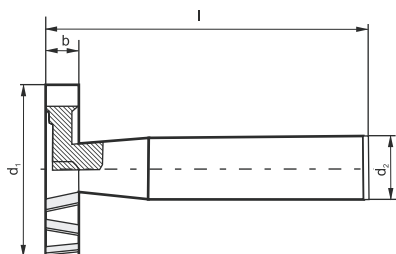

Series						SG61	SG62	SG63	SG64	SG65	SG66
	Material					HSS	Co 5%	HSS	Co 5%	HSS	Co 5%
	Type of shank					straight	straight	weldon	weldon	screwed	screwed
	d <sub>1</sub>	l	b	d <sub>2</sub>	Z	price EUR					
	mm	mm	mm	mm	A	each	each	each	each	each	each
045010	4,5	50	1	6	10	17,760	23,088	18,648	24,240	18,648	24,240
075015	7,5	50	1,5	6	10	19,200	24,960	20,160	26,208	20,160	26,208
075020	7,5	50	2	6	10	19,200	24,960	20,160	26,208	20,160	26,208
105020	10,5	50	2	6	10	21,600	28,080	22,680	29,484	22,680	29,484
105025	10,5	50	2,5	6	10	21,600	28,080	22,680	29,484	22,680	29,484
105030	10,5	50	3	6	10	21,600	28,080	22,680	29,484	22,680	29,484
135030	13,5	56	3	10	10	24,000	31,200	25,200	32,760	25,200	32,760
135040	13,5	56	4	10	10	24,000	31,200	25,200	32,760	25,200	32,760
165030	16,5	56	3	10	10	25,920	33,696	27,216	35,376	27,216	35,376
165040	16,5	56	4	10	10	25,920	33,696	27,216	35,376	27,216	35,376
165050	16,5	56	5	10	10	25,920	33,696	27,216	35,376	27,216	35,376
195040	19,5	63	4	10	10	37,760	49,088	39,648	51,536	39,648	51,536
195050	19,5	63	5	10	12	37,760	49,088	39,648	51,536	39,648	51,536
195060	19,5	63	6	10	12	37,760	49,088	39,648	51,536	39,648	51,536
225050	22,5	63	5	10	12	44,256	57,408	46,368	60,272	46,368	60,272
225060	22,5	63	6	10	12	44,256	57,408	46,368	60,272	46,368	60,272
225080	22,5	63	8	10	12	44,256	57,408	46,368	60,272	46,368	60,272
255060	25,5	63	6	10	14	56,960	74,048	59,808	77,744	59,808	77,744
285060	28,5	63	6	10	16	64,000	83,200	67,200	87,360	67,200	87,360
285080	28,5	63	8	10	16	64,000	83,200	67,200	87,360	67,200	87,360
285100	28,5	71	10	12	16	64,000	83,200	67,200	87,360	67,200	87,360
325070	32,5	71	7	12	18	71,040	92,352	74,592	96,976	74,592	96,976
325080	32,5	71	8	12	18	71,040	92,352	74,592	96,976	74,592	96,976
325100	32,5	71	10	12	18	71,040	92,352	74,592	96,976	74,592	96,976
455100	45,5	71	10	12	22	138,240	179,712	145,152	188,704	145,152	188,704

\*Posebno označene cijene ( **bold** ) odnose se na robu koju imamo na lageru. Za ostali asortiman rabate i rokove isporuke dajemo na osnovu upita.

\*Prices given in **bold** figures refer to products on stock. Discount and delivery terms for other product assortment are given at request.

\*Die separat gekennzeichneten Prices ( **bold** ) beziehen sich auf die Ware, die auf Lager liegt. Die Rabatte und Lieferzeiten für das restliche Sortiment geben wir auf Anfrage bekannt.

**T - GLODALA ZA ŽLIJEB, VALJKASTA DRŠKA**

**T - SLOT CUTTERS, STRAIGHT SHANK**

**T - NUTENFRÄSER, ZYLINDERSCHAFT**

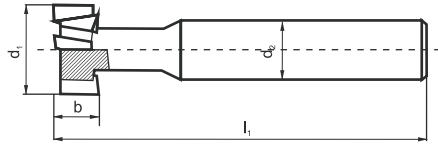

Series	Material					SG71	SG72	SG73	SG74	SG75	SG76
	Type of shank					straight	straight	weldon	weldon	screwed	screwed
	d <sub>1</sub>	l <sub>1</sub>	b	d <sub>2</sub>	Z	price EUR					
	mm	mm	mm	mm		each	each	each	each	each	each
110040	11	53,5	4	10	6	29,088	36,360	30,540	38,184	30,540	38,184
125060	12,5	57	6	10	6	29,088	36,360	30,540	38,184	30,540	38,184
160080	16	62	8	10	6	35,520	44,400	37,296	46,620	37,296	46,620
180080	18	70	8	12	6	51,840	64,800	54,432	68,048	54,432	68,048
210090	21	74	9	12	8	58,240	72,800	61,152	76,448	61,152	76,448
250110	25	82	11	16	8	79,360	99,200	83,328	104,160	83,328	104,160
320140	32	90	14	16	8	94,720	118,400	99,456	124,320	99,456	124,320
400180	40	108	18	25	10	163,200	204,000	171,360	214,208	171,360	214,208
500220	50	124	22	32	10	254,720	318,400	267,456	334,320	267,456	334,320

**DIN 851 B**

**T - GLODALA ZA ŽLIJEB, MK DRŠKA**

**T - SLOT CUTTERS, MORSE TAPER SHANK**

**T - NUTENFRASER, MORSEKEGELSCHAFT**

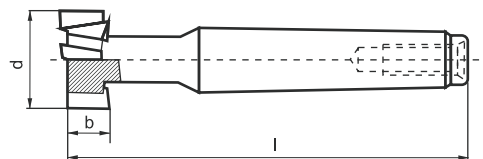

Series	Material						SG78	SG79
	Type of shank						HSS	Co 5%
	d	l	b	MT	Z	price EUR		
	mm	mm	mm			each	each	
180080	18	82	8	1	6	60,160	75,200	
210090	21	102	9	2	8	69,120	86,400	
250110	25	104	11	2	8	88,960	111,200	
320140	32	111	14	2	8	102,400	128,000	
400180	40	140	18	3	10	193,920	242,400	
500220	50	187	22	4	10	268,800	336,000	
600280	60	201	28	4	12	326,400	408,000	
720350	72	248	35	5	14	464,000	580,000	
850450	85	255	40	5	14	552,320	690,400	
950440	95	264	44	5	14	640,000	800,000	

\*Posebno označene cijene ( **bold** ) odnose se na robu koju imamo na lageru. Za ostali asortiman rabate i rokove isporuke dajemo na osnovu upita.

\*Prices given in **bold** figures refer to products on stock. Discount and delivery terms for other product assortment are given at request.

\*Die separat gekennzeichneten Prices ( **bold** ) beziehen sich auf die Ware, die auf Lager liegt. Die Rabatte und Lieferzeiten für das restliche Sortiment geben wir auf Anfrage bekannt.

GLODALA UGAONA, VALJKASTA DRŠKA

DOVETAIL CUTTERS, STRAIGHT SHANK

WINKELFRÄSER, ZYLINDERSCHAFT

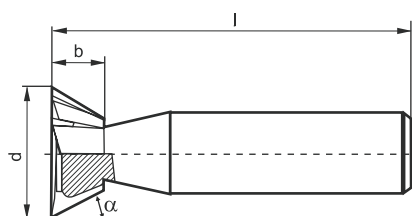

DIN 1833 - A



DIN 1833 - B



Series						SG81	SG82	SG83	SG84	SG85	SG86	SG87	SG88
	Material					HSS	Co 5%	HSS	Co 5%	HSS	Co 5%	HSS	Co 5%
	Type of shank					straight	straight	screwed	screwed	straight	straight	screwed	screwed
	d <sub>1</sub>	l <sub>1</sub>	b	α	Z	price EUR							
	mm	mm	mm			each	each	each	each	each	each	each	each
16045	16	60	4	45°	10	39,040	46,848	42,944	51,536	39,040	46,848	42,944	51,536
20045	20	63	5	45°	10	45,440	54,528	49,984	59,984	45,440	54,528	49,984	59,984
25045	25	67	6,3	45°	10	64,640	77,568	71,104	85,328	64,640	77,568	71,104	85,328
16060	16	60	6,3	60°	10	39,040	46,848	42,944	51,536	39,040	46,848	42,944	51,536
20060	20	63	8	60°	10	45,440	54,528	49,984	59,984	45,440	54,528	49,984	59,984
25060	25	67	10	60°	10	64,640	77,568	71,104	85,328	64,640	77,568	71,104	85,328
16070	16	60	7	70°	10	39,040	46,848	42,944	51,536	39,040	46,848	42,944	51,536
20070	20	63	9	70°	10	45,440	54,528	49,984	59,984	45,440	54,528	49,984	59,984
25070	25	67	11	70°	10	64,640	77,568	71,104	85,328	64,640	77,568	71,104	85,328

\*Posebno označene cijene ( **bold** ) odnose se na robu koju imamo na lageru. Za ostali asortiman rabate i rokove isporuke dajemo na osnovu upita.

\*Prices given in **bold** figures refer to products on stock. Discount and delivery terms for other product assortment are given at request.

\*Die separat gekennzeichneten Prices ( **bold** ) beziehen sich auf die Ware, die auf Lager liegt. Die Rabatte und Lieferzeiten für das restliche Sortiment geben wir auf Anfrage bekannt.

**GLODALA VREtenASTA, SK DRŠKA (DIN 2080)**

**END MILLS, 7/24 TAPER SHANK (DIN 2080)**

**SCHAFTFRÄSER, STEILKEGELSCHAFT (DIN 2080)**

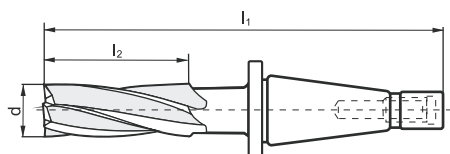

Series	Material					SG91	SG92
	d	l <sub>1</sub>	l <sub>2</sub>	Z	SK	HSS	Co 5%
						price EUR	
mm	mm	mm			each	each	
32188	32	188	53	6	40	172,800	216,000
32241	32	241	106	6	40	230,400	288,000
36188	36	188	53	6	40	187,520	234,400
36241	36	241	106	6	40	254,720	318,400
40198	40	198	63	6	40	214,400	268,000
40260	40	260	125	6	40	339,840	424,800
45198	45	198	63	8	40	264,320	330,400
45260	45	260	125	8	40	376,320	470,400
50210	50	210	75	8	40	307,200	384,000
50285	50	285	150	8	40	456,320	570,400
56210	56	210	75	8	40	390,400	488,000
56285	56	285	150	8	40	608,000	760,000
40240	40	240	63	6	50	334,720	418,400
40302	40	302	150	6	50	448,000	560,000
45240	45	240	63	6	50	408,320	510,400
45302	45	302	150	6	50	568,320	710,400
50252	50	252	75	6	50	393,600	492,000
50327	50	327	150	6	50	544,000	680,000
56252	56	252	75	8	50	472,320	590,400
56327	56	327	150	8	50	656,000	820,000
63267	63	267	90	8	50	560,000	700,000
63357	63	357	180	8	50	800,000	1.000,000
80283	80	283	106	8	50	896,000	1.120,000
80389	80	389	212	8	50	1.233,920	1.542,400

\*Posebno označene cijene ( **bold** ) odnose se na robu koju imamo na lageru. Za ostali asortiman rabate i rokove isporuke dajemo na osnovu upita.

\*Prices given in **bold** figures refer to products on stock. Discount and delivery terms for other product assortment are given at request.

\*Die separat gekennzeichneten Prices ( **bold** ) beziehen sich auf die Ware, die auf Lager liegt. Die Rabatte und Lieferzeiten für das restliche Sortiment geben wir auf Anfrage bekannt.

RAZVRTAČI RUČNI, VALJKASTA DRŠKA

HAND REAMERS, STRAIGHT SHANK

HANDREIBAHLEN, ZYLINDERSCHAFT

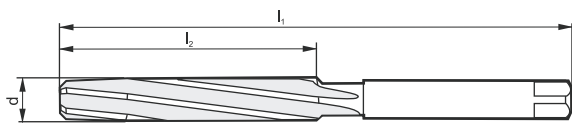

Series				SR01	SR02	SR03	SR04
	Material			HSS	Co 5%	HSS	Co 5%
	Type			A	A	B	B
	d	l <sub>1</sub>	l <sub>2</sub>	price EUR			
mm	mm	mm	each	each	each	each	
00200	2	50	25	9,380	14,070	9,380	14,070
00220	2,2	54	27	10,570	15,862	10,570	15,862
00250	2,5	58	29	9,660	14,490	9,660	14,490
00280	2,8	62	31	11,410	17,122	11,410	17,122
00300	3	62	31	10,500	15,750	10,500	15,750
00320	3,2	66	33	10,920	16,380	10,920	16,380
00350	3,5	71	35	10,920	16,380	10,920	16,380
00400	4	76	38	10,920	16,380	10,920	16,380
00450	4,5	81	41	12,530	18,802	12,530	18,802
00500	5	87	44	12,250	18,382	12,250	18,382
00550	5,5	93	47	13,580	20,370	13,580	20,370
00600	6	93	47	12,670	19,012	12,670	19,012
00700	7	107	54	13,580	20,370	13,580	20,370
00800	8	115	58	14,420	21,630	14,420	21,630
00900	9	124	62	16,170	24,262	16,170	24,262
01000	10	133	66	16,800	25,200	16,800	25,200
01100	11	142	71	17,920	26,880	17,920	26,880
01200	12	152	76	19,670	29,512	19,670	29,512
01300	13	152	76	24,480	36,720	24,480	36,720
01400	14	163	81	27,520	41,280	27,520	41,280
01500	15	163	81	30,000	45,008	30,000	45,008
01600	16	175	87	32,000	48,000	32,000	48,000
01700	17	175	87	34,960	52,448	34,960	52,448
01800	18	188	93	37,040	55,568	37,040	55,568
01900	19	188	93	43,520	65,280	43,520	65,280
02000	20	201	100	44,000	66,000	44,000	66,000
02200	22	215	107	50,000	75,008	50,000	75,008
02400	24	231	115	61,040	91,568	61,040	91,568
02500	25	231	115	63,040	94,560	63,040	94,560
02600	26	231	115	69,040	103,568	69,040	103,568

\*Posebno označene cijene ( **bold** ) odnose se na robu koju imamo na lageru. Za ostali asortiman rabate i rokove isporuke dajemo na osnovu upita.

\*Prices given in **bold** figures refer to products on stock. Discount and delivery terms for other product assortment are given at request.

\*Die separat gekennzeichneten Prices ( **bold** ) beziehen sich auf die Ware, die auf Lager liegt. Die Rabatte und Lieferzeiten für das restliche Sortiment geben wir auf Anfrage bekannt.

Series				SR01	SR02	SR03	SR04
	Material			HSS	Co 5%	HSS	Co 5%
	Type			A	A	B	B
	d	l <sub>1</sub>	l <sub>2</sub>	price EUR			
mm	mm	mm	each	each	each	each	
02800	28	247	124	78,000	117,008	78,000	117,008
03000	30	247	124	85,040	127,568	85,040	127,568
03200	32	265	133	100,000	150,000	100,000	150,000
03400	34	284	142	130,000	195,008	130,000	195,008
03500	35	284	142	124,000	186,000	124,000	186,000
03600	36	284	142	145,040	217,568	145,040	217,568
03800	38	305	152	160,000	240,000	160,000	240,000
04000	40	305	152	160,000	240,000	160,000	240,000
04200	42	305	152	192,800	289,200	192,800	289,200
04400	44	326	163	245,600	368,400	245,600	368,400
04500	45	326	163	224,800	337,200	224,800	337,200
04600	46	326	163	296,800	445,200	296,800	445,200
04800	48	347	174	317,600	476,400	317,600	476,400
05000	50	347	174	284,800	427,200	284,800	427,200

\*Posebno označene cijene ( **bold** ) odnose se na robu koju imamo na lageru. Za ostali asortiman rabate i rokove isporuke dajemo na osnovu upita.

\*Prices given in **bold** figures refer to products on stock. Discount and delivery terms for other product assortment are given at request.

\*Die separat gekennzeichneten Prices ( **bold** ) beziehen sich auf die Ware, die auf Lager liegt. Die Rabatte und Lieferzeiten für das restliche Sortiment geben wir auf Anfrage bekannt.



RAZVRTAČI MAŠNSKI, MK DRŠKA

MACHINE REAMERS, MORSE TAPER SHANK

MASCHINENREIBAHLEN, MORSEKEGELSCHAFT



Series					SR11	SR12	SR13	SR14
	Material				HSS	Co 5%	HSS	Co 5%
	Type				A	A	B	B
	d	l <sub>1</sub>	l <sub>2</sub>	MT	price EUR			
mm	mm	mm	each		each	each	each	
00300	3	125	20	1	22,000	33,008	22,000	33,008
00400	4	133	22	1	21,680	33,008	21,680	33,008
00500	5	133	23	1	22,480	33,728	22,480	33,728
00600	6	138	26	1	23,520	34,560	23,520	34,560
00700	7	150	31	1	23,520	35,280	23,520	35,280
00800	8	156	33	1	23,520	35,280	23,520	35,280
00900	9	162	36	1	26,480	39,728	26,480	39,728
01000	10	168	38	1	25,040	37,568	25,040	37,568
01100	11	175	41	1	26,480	39,728	26,480	39,728
01200	12	182	44	1	26,480	39,728	26,480	39,728
01300	13	182	44	1	27,680	42,720	27,680	42,720
01400	14	189	47	1	28,000	43,008	28,000	43,008
01500	15	204	50	2	28,960	43,440	28,960	43,440
01600	16	210	52	2	31,520	47,280	31,520	47,280
01700	17	214	54	2	34,000	51,008	34,000	51,008
01800	18	219	56	2	35,008	52,496	35,008	52,496
01900	19	223	58	2	38,480	57,728	38,480	57,728
02000	20	228	60	2	38,480	57,728	38,480	57,728
02100	21	232	62	2	44,480	66,720	44,480	66,720
02200	22	237	64	2	44,000	66,000	44,000	66,000
02300	23	241	66	2	49,520	74,288	49,520	74,288
02400	24	268	68	3	51,040	76,560	51,040	76,560
02500	25	268	68	3	52,960	79,440	52,960	79,440
02600	26	273	70	3	58,960	88,448	58,960	88,448
02700	27	277	71	3	66,960	100,448	66,960	100,448
02800	28	277	71	3	62,960	94,448	62,960	94,448
02900	29	281	73	3	72,960	109,440	72,960	109,440
03000	30	281	73	3	72,000	108,000	72,000	108,000
03100	31	285	75	3	84,960	127,440	84,960	127,440
03200	32	317	77	4	86,000	129,008	86,000	129,008

\*Posebno označene cijene ( **bold** ) odnose se na robu koju imamo na lageru. Za ostali asortiman rabate i rokove isporuke dajemo na osnovu upita.

\*Prices given in **bold** figures refer to products on stock. Discount and delivery terms for other product assortment are given at request.

\*Die separat gekennzeichneten Prices ( **bold** ) beziehen sich auf die Ware, die auf Lager liegt. Die Rabatte und Lieferzeiten für das restliche Sortiment geben wir auf Anfrage bekannt.

Series					SR11	SR12	SR13	SR14
	Material				HSS	Co 5%	HSS	Co 5%
	Type				A	A	B	B
	d	l <sub>1</sub>	l <sub>2</sub>	MT	price EUR			
mm	mm	mm	each		each	each	each	
03300	33	317	77	4	104,960	157,440	104,960	157,440
03400	34	321	78	4	104,000	156,000	104,000	156,000
03500	35	321	78	4	104,000	156,000	104,000	156,000
03600	36	325	79	4	114,000	171,008	114,000	171,008
03800	38	329	81	4	127,040	190,560	127,040	190,560
04000	40	329	81	4	132,000	198,000	132,000	198,000
04200	42	333	82	4	140,000	210,000	140,000	210,000
04400	44	336	83	4	170,000	255,008	170,000	255,008
04500	45	336	83	4	161,040	241,568	161,040	241,568
04600	46	340	84	4	173,040	259,568	173,040	259,568
04700	47	340	84	4	208,000	312,000	208,000	312,000
04800	48	344	86	4	190,000	285,008	190,000	285,008
05000	50	344	86	4	205,040	307,568	205,040	307,568

\*Posebno označene cijene ( **bold** ) odnose se na robu koju imamo na lageru. Za ostali asortiman rabate i rokove isporuke dajemo na osnovu upita.

\*Prices given in **bold** figures refer to products on stock. Discount and delivery terms for other product assortment are given at request.

\*Die separat gekennzeichneten Prices ( **bold** ) beziehen sich auf die Ware, die auf Lager liegt. Die Rabatte und Lieferzeiten für das restliche Sortiment geben wir auf Anfrage bekannt.

RAZVRTAČI MAŠINSKI, VALJKASTA DRŠKA

MACHINE REAMERS, STRAIGHT SHANK

MASCHINENREIBAHLEN, ZYLINDERSCHAFT

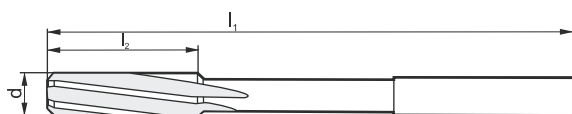

Series	Material			SR21	SR22	SR23	SR24
	Type			HSS	Co 5%	HSS	Co 5%
	d	l <sub>1</sub>	l <sub>2</sub>	C	C	D	D
	mm	mm	mm	price EUR			
				each	each	each	each
00200	2	49	11	8,880	13,328	8,880	13,328
00220	2,2	53	12	9,920	14,880	9,920	14,880
00250	2,5	57	14	9,280	13,920	9,280	13,920
00280	2,8	61	15	10,080	15,120	10,080	15,120
00300	3	61	15	9,040	13,568	9,040	13,568
00320	3,2	65	16	10,000	15,008	10,000	15,008
00350	3,5	70	18	10,000	15,008	10,000	15,008
00400	4	75	19	10,240	15,360	10,240	15,360
00450	4,5	80	21	10,800	16,208	10,800	16,208
00500	5	86	23	10,880	16,320	10,880	16,320
00550	5,5	93	26	11,520	17,280	11,520	17,280
00600	6	93	26	11,520	17,280	11,520	17,280
00650	6,5	101	28	13,040	19,568	13,040	19,568
00700	7	109	31	13,040	19,568	13,040	19,568
00800	8	117	33	14,240	21,360	14,240	21,360
00900	9	125	36	16,480	24,720	16,480	24,720
01000	10	133	38	18,000	27,008	18,000	27,008
01100	11	142	41	22,480	33,728	22,480	33,728
01200	12	151	44	23,040	34,560	23,040	34,560
01300	13	151	44	25,040	37,568	25,040	37,568
01400	14	160	47	27,040	40,560	27,040	40,560
01500	15	162	50	28,000	42,000	28,000	42,000
01600	16	170	52	30,000	45,008	30,000	45,008
01700	17	175	54	34,000	51,008	34,000	51,008
01800	18	182	56	35,040	52,560	35,040	52,560
01900	19	189	58	42,000	63,008	42,000	63,008
02000	20	195	60	40,000	60,000	40,000	60,000
02100	21	215	55	59,040	88,560	59,040	88,560
02200	22	225	55	54,000	81,008	54,000	81,008
02300	23	230	60	66,000	99,008	66,000	99,008
02400	24	240	60	61,040	91,568	61,040	91,568
02500	25	245	60	62,000	93,008	62,000	93,008
02600	26	250	60	72,000	108,000	72,000	108,000
02700	27	260	60	87,040	130,560	87,040	130,560
02800	28	270	65	89,040	133,568	89,040	133,568
02900	29	270	65	106,000	159,008	106,000	159,008
03000	30	280	70	104,000	156,000	104,000	156,000
03100	31	290	75	126,000	189,008	126,000	189,008

\*Posebno označene cijene ( **bold** ) odnose se na robu koju imamo na lageru. Za ostali asortiman rabate i rokove isporuke dajemo na osnovu upita.

\*Prices given in **bold** figures refer to products on stock. Discount and delivery terms for other product assortment are given at request.

\*Die separat gekennzeichneten Prices ( **bold** ) beziehen sich auf die Ware, die auf Lager liegt. Die Rabatte und Lieferzeiten für das restliche Sortiment geben wir auf Anfrage bekannt.

RAZVRTAČI ZA RUPE ZAKIVAKA, MT DRŠKA

BRIDGE REAMERS, MORSE TAPER SHANK

NIETLOCHREIBAHLEN, MORSEKEGELSCHAFT

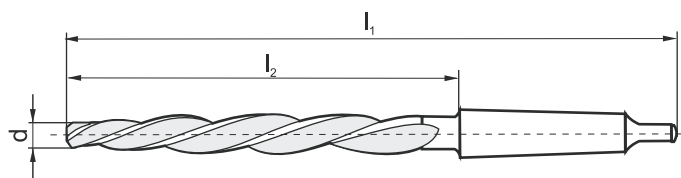

Series	Material				SR37	SR38
	Type				HSS	Co 5%
	d	l <sub>1</sub>	l <sub>2</sub>	MT	B	B
					price EUR	
	mm	mm	mm		each	each
00640	6,4	151	75	1	42,552	63,828
00740	7,4	156	80	1	42,552	63,828
00840	8,4	161	85	1	42,552	63,828
00950	9,5	166	90	1	42,552	63,828
01000	10	171	95	1	42,552	63,828
01100	11	176	100	1	42,552	63,828
01200	12	199	105	2	43,200	64,800
01300	13	199	105	2	43,200	64,800
01400	14	209	115	2	47,995	71,928
01500	15	219	125	2	47,088	70,632
01600	16	229	135	2	54,000	81,000
01700	17	238	135	2	58,104	87,156
01800	18	261	145	3	63,504	95,256
01900	19	261	145	3	66,204	99,306
02000	20	271	155	3	71,604	107,406
02100	21	271	155	3	74,304	111,456
02200	22	281	165	3	82,404	123,606
02300	23	281	165	3	85,104	127,656
02400	24	296	180	3	89,100	133,650
02500	25	296	180	3	91,800	137,700
02600	26	296	180	3	104,004	156,006
02700	27	311	195	3	114,804	172,206
02800	28	311	195	3	122,904	184,356
02900	29	311	195	3	141,804	212,706
03000	30	311	195	3	147,204	220,806
03100	31	326	210	3	168,804	253,206
03200	32	354	210	4	178,200	267,300
03300	33	354	210	4	189,000	283,500
03400	34	364	220	4	199,800	299,700
03600	36	364	220	4	221,400	332,100
03700	37	364	220	4	229,500	344,250
04000	40	374	230	4	263,304	394,956

\*Posebno označene cijene ( **bold** ) odnose se na robu koju imamo na lageru. Za ostali asortiman rabate i rokove isporuke dajemo na osnovu upita.

\*Prices given in **bold** figures refer to products on stock. Discount and delivery terms for other product assortment are given at request.

\*Die separat gekennzeichneten Prices ( **bold** ) beziehen sich auf die Ware, die auf Lager liegt. Die Rabatte und Lieferzeiten für das restliche Sortiment geben wir auf Anfrage bekannt.

RAZVRTAČI KUPASTI 1:50, VALJKASTA DRŠKA

HAND TAPER PIN REAMERS, TAPER 1:50 STRAIGHT SHANK

HAND-KEGELREIBAHLEN, KEGEL 1:50, ZYLINDERSCHAFT

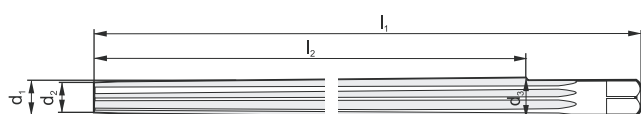

Series						SR31	SR32	SR33	SR34
	Material					HSS	Co 5%	HSS	Co 5%
	Type					A	A	B	B
	d <sub>1</sub>	l <sub>1</sub>	l <sub>2</sub>	d <sub>2</sub>	d <sub>3</sub>	price EUR			
	mm	mm	mm	mm	mm	each	each	each	each
00300	3	80	58	2,9	4,06	12,600	18,900	12,600	18,900
00400	4	93	68	3,9	5,26	13,776	20,664	13,776	20,664
00500	5	100	73	4,9	6,36	17,892	26,838	17,892	26,838
00600	6	135	105	5,9	8,00	22,092	33,138	22,092	33,138
00650	6,5	148	118	6,4	8,76	23,604	35,406	23,604	35,406
00700	7	160	130	6,9	9,50	29,904	44,856	29,904	44,856
00800	8	180	145	7,9	10,80	36,204	54,306	36,204	54,306
00900	9	190	152	8,9	11,94	43,596	65,394	43,596	65,394
01000	10	215	175	9,9	13,40	44,604	66,906	44,604	66,906
01200	12	255	210	11,8	16,00	63,000	94,500	63,000	94,500
01300	13	255	210	12,8	17,00	81,600	122,400	81,600	122,400
01400	14	255	210	13,8	18,00	84,000	126,000	84,000	126,000
01600	16	280	230	15,8	20,40	104,400	156,608	104,400	156,608
02000	20	310	250	19,8	24,80	132,000	198,000	132,000	198,000
02500	25	370	300	24,7	30,70	226,800	340,200	226,800	340,200
03000	30	400	320	29,7	36,10	286,200	429,300	286,200	429,300
04000	40	430	340	39,7	46,50	462,024	693,036	462,024	693,036
05000	50	460	360	49,7	56,90	788,400	1182,600	788,400	1182,600

\*Posebno označene cijene ( **bold** ) odnose se na robu koju imamo na lageru. Za ostali asortiman rabate i rokove isporuke dajemo na osnovu upita.

\*Prices given in **bold** figures refer to products on stock. Discount and delivery terms for other product assortment are given at request.

\*Die separat gekennzeichneten Prices ( **bold** ) beziehen sich auf die Ware, die auf Lager liegt. Die Rabatte und Lieferzeiten für das restliche Sortiment geben wir auf Anfrage bekannt.

**RAZVRTAČI MAŠINSKI, NASADNI**

**SHELL REAMERS**

**AUFSTECK - REIBAHLEN**

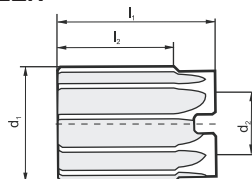

Series					SR91	SR92	SR93	SR94
	Material				HSS	Co 5%	HSS	Co 5%
	Type				A	A	B	B
	d <sub>1</sub>	l <sub>1</sub>	l <sub>2</sub>	d <sub>2</sub>	price EUR			
	mm	mm	mm	mm	each	each	each	each
02500	25	45	32	13	63,040	94,560	63,040	94,560
02600	26	45	32	13	66,400	99,600	66,400	99,600
02700	27	45	32	13	75,040	112,560	75,040	112,560
02800	28	45	32	13	68,000	102,000	68,000	102,000
02900	29	45	32	13	75,040	112,560	75,040	112,560
03000	30	45	32	13	69,040	103,568	69,040	103,568
03100	31	50	36	16	85,040	127,568	85,040	127,568
03200	32	50	36	16	75,040	112,560	75,040	112,560
03300	33	50	36	16	81,008	121,504	81,008	121,504
03400	34	50	36	16	81,008	121,504	81,008	121,504
03500	35	50	36	16	80,000	120,000	80,000	120,000
03600	36	56	40	19	88,000	132,000	88,000	132,000
03700	37	56	40	19	102,000	153,008	102,000	153,008
03800	38	56	40	19	96,000	144,000	96,000	144,000
04000	40	56	40	19	96,000	144,000	96,000	144,000
04200	42	56	40	19	102,000	153,008	102,000	153,008
04400	44	63	45	22	129,008	193,504	129,008	193,504
04500	45	63	45	22	123,008	184,496	123,008	184,496
04600	46	63	45	22	136,000	204,000	136,000	204,000
04700	47	63	45	22	137,600	206,400	137,600	206,400
04800	48	63	45	22	138,000	207,008	138,000	207,008
05000	50	63	45	22	138,000	207,008	138,000	207,008
05200	52	71	50	27	165,040	247,568	165,040	247,568
05500	55	71	50	27	168,000	252,000	168,000	252,000
05800	58	71	50	27	190,000	285,008	190,000	285,008
06000	60	71	50	27	190,000	285,008	190,000	285,008
06200	62	80	56	32	228,000	342,000	228,000	342,000
06500	65	80	56	32	232,000	348,000	232,000	348,000
06800	68	80	56	32	285,040	427,568	285,040	427,568
07000	70	80	56	32	274,000	411,008	274,000	411,008
07200	72	90	63	40	311,840	467,760	311,840	467,760
07500	75	90	63	40	329,040	493,568	329,040	493,568
07800	78	90	63	40	432,000	648,000	432,000	648,000
08000	80	90	63	40	393,040	589,568	393,040	589,568
08200	82	90	63	40	460,000	690,000	460,000	690,000
08500	85	90	63	40	460,000	690,000	460,000	690,000
08800	88	100	71	50	470,000	705,008	470,000	705,008
09000	90	100	71	50	500,000	750,000	500,000	750,000
09200	92	100	71	50	670,000	1005,008	670,000	1005,008
09500	95	100	71	50	670,000	1005,008	670,000	1005,008
09800	98	100	71	50	680,000	1020,000	680,000	1020,000
10000	100	100	71	50	690,000	1035,008	690,000	1035,008

\*Posebno označene cijene ( **bold** ) odnose se na robu koju imamo na lageru. Za ostali asortiman rabate i rokove isporuke dajemo na osnovu upita.

\*Prices given in **bold** figures refer to products on stock. Discount and delivery terms for other product assortment are given at request.

\*Die separat gekennzeichneten Prices ( **bold** ) beziehen sich auf die Ware, die auf Lager liegt. Die Rabatte und Lieferzeiten für das restliche Sortiment geben wir auf Anfrage bekannt.



UPUŠTAČI SPIRALNI, MK DRŠKA

CORE DRILLS, MORSE TAPER SHANK

AUFBOHRER, MORSEKEGELSCHAFT

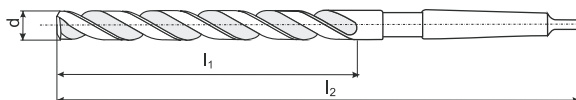

Series	Material			SU06	SU07
	d	l <sub>1</sub>	l <sub>2</sub>	HSS	Co 5%
	mm	mm	mm	price EUR	
00800	8	156	75	28,224	36,688
00900	9	162	81	33,024	42,928
01000	10	168	87	33,024	42,928
01100	11	175	94	33,600	43,680
01200	12	182	101	34,176	44,432
01300	13	182	101	36,576	47,552
01400	14	189	108	38,400	49,920
01500	15	212	114	39,648	51,536
01600	16	218	120	43,776	56,912
01700	17	223	125	45,600	59,280
01800	18	228	130	48,000	62,400
01900	19	233	135	52,800	68,640
02000	20	238	140	54,624	71,008
02100	21	243	145	60,000	78,000
02200	22	248	150	63,648	82,736
02300	23	253	155	70,848	92,096
02400	24	281	160	74,400	96,720
02500	25	281	160	79,200	102,960
02600	26	286	165	91,200	118,560
02700	27	291	170	97,248	126,416
02800	28	291	170	100,800	131,040
02900	29	296	175	109,248	142,016
03000	30	296	175	112,800	146,640
03100	31	301	180	130,848	170,096
03200	32	334	185	153,600	199,680
03300	33	334	185	153,600	199,680
03400	34	339	190	157,248	204,416
03500	35	339	190	159,648	207,536
03600	36	344	195	172,800	224,640
03700	37	344	195	187,200	243,360
03800	38	349	200	189,600	246,480

\*Posebno označene cijene ( **bold** ) odnose se na robu koju imamo na lageru. Za ostali asortiman rabate i rokove isporuke dajemo na osnovu upita.

\*Prices given in **bold** figures refer to products on stock. Discount and delivery terms for other product assortment are given at request.

\*Die separat gekennzeichneten Prices ( **bold** ) beziehen sich auf die Ware, die auf Lager liegt. Die Rabatte und Lieferzeiten für das restliche Sortiment geben wir auf Anfrage bekannt.

UPUŠTAČI ČEONI SA KRUTOM VOĐICOM, VALJKASTA DRŠKA

COUNTERBORES WITH SOLID PILOT, STRAIGHT SHANK

FLACHSENKER MIT FESTEM FÜHRUNGSPFENNEN, ZYLINDERSCHAFT

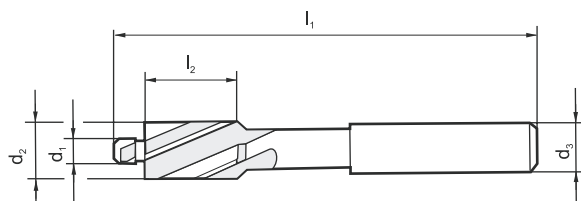

Series	Material						SU01	SU02
		for thread	d <sub>2</sub> mm	l <sub>1</sub> mm	l <sub>2</sub> mm	d <sub>1</sub> mm	d <sub>3</sub> mm	HSS
							price EUR	
							each	each
<i>FINE</i>								
F0300	M3	6	71	14	3,2	5	12,000	16,800
F0400	M4	8	71	14	4,3	5	12,000	16,800
F0500	M5	10	80	18	5,3	8	12,000	16,800
F0600	M6	11	80	18	6,4	8	13,020	18,228
F0800	M8	15	100	22	8,4	12,5	20,860	29,204
F1000	M10	18	100	22	10,5	12,5	26,000	36,400
F1200	M12	20	100	22	13	12,5	30,000	42,000
<i>MEDIUM</i>								
M0300	M3	6	71	14	3,4	5	12,000	16,800
M0400	M4	8	71	14	4,5	5	12,000	16,800
M0500	M5	10	80	18	5,5	8	12,000	16,800
M0600	M6	11	80	18	6,6	8	13,020	18,228
M0800	M8	15	100	22	9	12,5	20,860	29,204
M1000	M10	18	100	22	11	12,5	26,000	36,400
M1200	M12	20	100	22	14	12	30,000	42,000
<i>CORE HOLE</i>								
C0300	M3	6	71	14	2,5	5	12,000	16,800
C0400	M4	8	71	14	3,3	5	12,000	16,800
C0500	M5	10	80	18	4,2	8	12,000	16,800
C0600	M6	11	80	18	5	8	13,020	18,228
C0800	M8	15	100	22	6,8	12,5	20,860	29,204
C1000	M10	18	100	22	8,5	12,5	26,000	36,400
C1200	M12	20	100	22	10,2	12,5	30,000	42,000

\*Posebno označene cijene ( **bold** ) odnose se na robu koju imamo na lageru. Za ostali asortiman rabate i rokove isporuke dajemo na osnovu upita.

\*Prices given in **bold** figures refer to products on stock. Discount and delivery terms for other product assortment are given at request.

\*Die separat gekennzeichneten Prices ( **bold** ) beziehen sich auf die Ware, die auf Lager liegt. Die Rabatte und Lieferzeiten für das restliche Sortiment geben wir auf Anfrage bekannt.

UPUŠTAČI ČEONI SA KRUTOM VOĐICOM, MK DRŠKA

COUNTERBORES WITH SOLID PILOT, MORSE TAPER SHANK

FLACHSENKER MIT FESTEM FÜHRUNGZAPFEN, MORSEKEGELSCHAFT

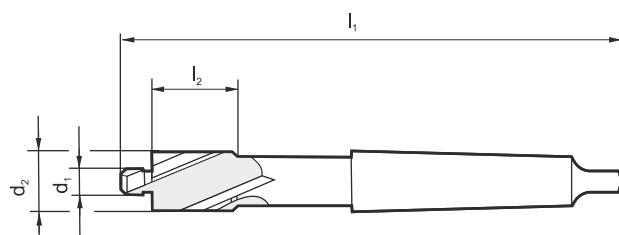

Series	Material					SU03	SU04
	for thread	d <sub>2</sub>	d <sub>1</sub>	l <sub>1</sub>	MT	HSS	Co 5%
		mm	mm	mm		price EUR	
						each	each
<b>FINE</b>							
F1000	M10	18	10.5	150	2	56,640	70,800
F1200	M12	20	13	150	2	59,328	74,160
F1400	M14	24	15	160	2	70,512	88,152
F1600	M16	26	17	190	3	82,128	102,672
F1800	M18	30	19	190	3	98,400	123,000
F2000	M20	33	21	190	3	110,400	138,000
F2200	M22	36	23	205	3	146,400	183,000
<b>MEDIUM</b>							
M1000	M10	18	11	150	2	56,640	70,800
M1200	M12	20	14	150	2	59,328	74,160
M1400	M14	24	16	160	2	70,512	88,152
M1600	M16	26	17.5	190	3	82,128	102,672
M1800	M18	30	20	190	3	98,400	123,000
M2000	M20	33	22	190	3	110,400	138,000
M2200	M22	36	24	205	3	146,400	183,000
<b>CORE HOLE</b>							
C1000	M10	18	8.5	150	2	56,640	70,800
C1200	M12	20	10.2	150	2	59,328	74,160
C1400	M14	24	12	160	2	70,512	88,152
C1600	M16	26	14	190	3	82,128	102,672
C1800	M18	30	15.5	190	3	98,400	123,000
C2000	M20	33	17.5	190	3	110,400	138,000
C2200	M22	36	19.5	205	3	146,400	183,000

\*Posebno označene cijene ( **bold** ) odnose se na robu koju imamo na lageru. Za ostali asortiman rabate i rokove isporuke dajemo na osnovu upita.

\*Prices given in **bold** figures refer to products on stock. Discount and delivery terms for other product assortment are given at request.

\*Die separat gekennzeichneten Prices ( **bold** ) beziehen sich auf die Ware, die auf Lager liegt. Die Rabatte und Liferzeiten für das restliche Sortiment geben wir auf Anfrage bekannt.

UPUŠTAČI KUPASTI SA RUPOM 90°

DEBURRING TOOLS 90°

ENGRATSENKER 90°

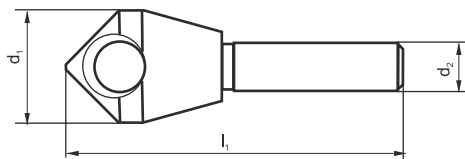

Series	Material				SU61	SU62
	N <sub>0</sub>	d <sub>1</sub> mm	l <sub>1</sub> mm	d <sub>2</sub> mm	price EUR	
					each	each
NO001	1	2-5	45	6	<b>9,280</b>	11,600
NO002	2	5-10	48	6	<b>11,840</b>	14,800
NO003	3	10-15	65	8	<b>23,200</b>	29,000
NO004	4	15-20	86	8	46,800	58,500
NO005	5	20-25	102	10	79,200	99,000
NO006	6	25-30	115	10	139,200	174,000
NO007	7	30-35	127	12	177,600	222,000
NO008	8	35-40	136	12	236,000	295,000
NO009	9	40-50	166	12	293,000	366,250

\*Posebno označene cijene ( **bold** ) odnose se na robu koju imamo na lageru. Za ostali asortiman rabate i rokove isporuke dajemo na osnovu upita.

\*Prices given in **bold** figures refer to products on stock. Discount and delivery terms for other product assortment are given at request.

\*Die separat gekennzeichneten Prices ( **bold** ) beziehen sich auf die Ware, die auf Lager liegt. Die Rabatte und Lieferzeiten für das restliche Sortiment geben wir auf Anfrage bekannt.

**UPUŠTAČI KUPASTI 60°, VALJKASTA DRŠKA**

**COUNTERSINKS 60°, STRAIGHT SHANK**

**KEGELSENKER 60°, ZYLINDERSCHAFT**

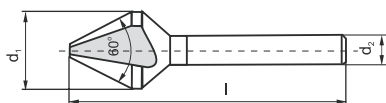

Series				SU35	SU36
	Material			HSS	Co 5%
	Type			C	C
	Number of flute			1	1
	d <sub>1</sub>	l	d <sub>2</sub>	price EUR	
	mm	mm	mm	each	each
00600	6	45	6	10,780	15,092
00800	8	50	8	11,620	16,268
01000	10	50	8	12,320	17,248
01200	12	50	8	15,680	21,952
01600	16	56	10	19,040	26,656
02000	20	60	10	28,140	39,396
02500	25	75	12	46,340	64,876
03000	30	80	12	60,760	85,064

**UPUŠTAČI KUPASTI 60°, MK DRŠKA**

**COUNTERSINKS 60°, MORSE TAPER SHANK**

**KEGELSENKER 60°, MORSEKEGELSCHAFT**

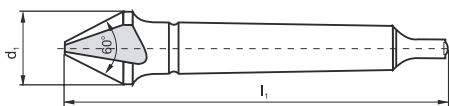

Series				SU37	SU38
	Material			HSS	Co 5%
	Type			D	D
	Number of flute			1	1
	d <sub>1</sub>	l <sub>1</sub>	MT	price EUR	
	mm	mm		each	each
01600	16	90	1	32,200	40,250
02000	20	106	2	40,600	50,750
02500	25	112	2	47,600	59,500
03150	31,5	118	2	74,200	92,750
04000	40	150	3	145,600	182,000
05000	50	160	3	236,600	295,750
06300	63	190	4	322,000	402,500
08000	80	200	4	597,800	747,250

\*Posebno označene cijene ( **bold** ) odnose se na robu koju imamo na lageru. Za ostali asortiman rabate i rokove isporuke dajemo na osnovu upita.

\*Prices given in **bold** figures refer to products on stock. Discount and delivery terms for other product assortment are given at request.

\*Die separat gekennzeichneten Prices ( **bold** ) beziehen sich auf die Ware, die auf Lager liegt. Die Rabatte und Lieferzeiten für das restliche Sortiment geben wir auf Anfrage bekannt.

**UPUŠTAČI KUPASTI 90°, VALJKASTA DRŠKA**

**COUNTERSINKS 90°, STRAIGHT SHANK**

**KEGELSENKER 90°, ZYLINDERSCHAFT**

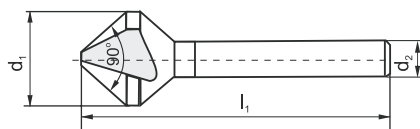

Series				SU39	SU40
Material				HSS	Co 5%
Type				C	C
Number of flute				1	1
	d <sub>1</sub>	l <sub>1</sub>	d <sub>2</sub>	price EUR	
	mm	mm	mm	each	each
00600	6	45	6	10,780	15,092
00800	8	50	8	11,620	16,268
01000	10	50	8	12,320	17,248
01200	12	50	8	15,680	21,952
01600	16	56	10	19,040	26,656
02000	20	60	10	28,140	39,396
02500	25	75	12	46,340	64,876
03000	30	80	12	60,760	85,064

**UPUŠTAČI KUPASTI 90°, MK DRŠKA**

**COUNTERSINKS 90°, MORSE TAPER SHANK**

**KEGELSENKER 90°, MORSEKEGELSCHAFT**

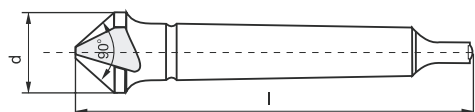

Series				SU41	SU42
Material				HSS	Co 5%
Type				D	D
Number of flute				1	1
	d	l	MT	price EUR	
	mm	mm		each	each
01600	16	90	1	32,200	40,250
02000	20	106	2	40,600	50,750
02500	25	112	2	47,600	59,500
03150	31,5	118	2	74,200	92,750
04000	40	150	3	145,600	182,000
05000	50	160	3	236,600	295,750
06300	63	190	4	322,000	402,500
08000	80	200	4	597,800	747,250

\*Posebno označene cijene ( **bold** ) odnose se na robu koju imamo na lageru. Za ostali asortiman rabate i rokove isporuke dajemo na osnovu upita.

\*Prices given in **bold** figures refer to products on stock. Discount and delivery terms for other product assortment are given at request.

\*Die separat gekennzeichneten Prices ( **bold** ) beziehen sich auf die Ware, die auf Lager liegt. Die Rabatte und Lieferzeiten für das restliche Sortiment geben wir auf Anfrage bekannt.



UPUŠTAČI KUPASTI 60°, VALJKASTA DRŠKA

COUNTERSINKS 60°, STRAIGHT SHANK

KEGELSENKER 60°, ZYLINDERSCHAFT

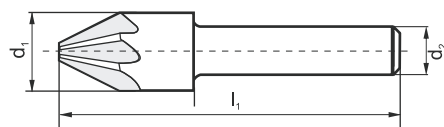

Series				SU11	SU12
	Material			HSS	Co 5%
	Type			A	A
	Number of flute			5-7	5-7
	d <sub>1</sub>	l <sub>1</sub>	d <sub>2</sub>	price EUR	
	mm	mm	mm	each	each
00800	8	50	8	11,480	16,072
01250	12,5	50	8	15,512	21,714
01600	16	60	10	18,200	25,480
02000	20	63	10	26,180	36,652

UPUŠTAČI KUPASTI 60°, MK DRŠKA

COUNTERSINKS 60°, MORSE TAPER SHANK

KEGELSENKER 60°, MORSEKEGELSCHAFT

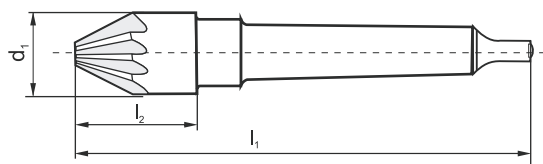

Series				SU13	SU14
	Material			HSS	Co 5%
	Type			B	B
	Number of flute			6-18	6-18
	d <sub>1</sub>	l <sub>1</sub>	MT	price EUR	
	mm	mm		each	each
01600	16	100	1	28,000	35,000
02500	25	125	2	38,500	48,132
03150	31,5	132	2	63,000	78,750
04000	40	160	3	126,000	157,500
05000	50	170	3	204,400	255,500
06300	63	200	4	352,800	441,000
08000	80	215	4	646,800	808,500

\*Posebno označene cijene ( **bold** ) odnose se na robu koju imamo na lageru. Za ostali asortiman rabate i rokove isporuke dajemo na osnovu upita.

\*Prices given in **bold** figures refer to products on stock. Discount and delivery terms for other product assortment are given at request.

\*Die separat gekennzeichneten Prices ( **bold** ) beziehen sich auf die Ware, die auf Lager liegt. Die Rabatte und Lieferzeiten für das restliche Sortiment geben wir auf Anfrage bekannt.

UPUŠTAČI KUPASTI 60°, VALJKASTA DRŠKA

COUNTERSINKS 60°, STRAIGHT SHANK

KEGELSENKER 60°, ZYLINDERSCHAFT

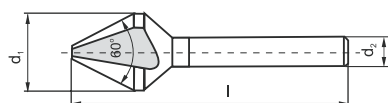

Series					SU15	SU16
Material					HSS	Co 5%
Type					C	C
Number of flute					3	3
	d <sub>1</sub>	l <sub>1</sub>	d <sub>2</sub>	d <sub>3</sub>	price EUR	
	mm	mm	mm	mm	each	each
00630	6,3	45	5	1,6	9,800	13,720
00800	8	50	6	2	11,508	16,114
01250	12,5	56	8	3,2	15,400	21,560
01600	16	63	10	4	18,200	25,480
02000	20	67	10	5	26,320	36,848
02500	25	71	10	6,3	46,900	65,660

UPUŠTAČI KUPASTI 60°, MK DRŠKA

COUNTERSINKS 60°, MORSE TAPER SHANK

KEGELSENKER 60°, MORSEKEGELSCHAFT

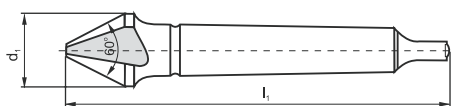

Series					SU17	SU18
Material					HSS	Co 5%
Type					D	D
Number of flute					3	3
	d <sub>1</sub>	l <sub>1</sub>	d <sub>2</sub>	MT	price EUR	
	mm	mm	mm		each	each
01600	16	90	4	1	25,200	31,500
02000	20	106	5	2	30,800	38,500
02500	25	112	6,3	2	35,000	43,750
03150	31,5	118	10	2	58,800	73,500
04000	40	150	12,5	3	116,200	145,250
05000	50	160	16	3	203,000	253,750
06300	63	190	20	4	336,000	420,000
08000	80	200	25	4	630,000	787,500

\*Posebno označene cijene ( **bold** ) odnose se na robu koju imamo na lageru. Za ostali asortiman rabate i rokove isporuke dajemo na osnovu upita.

\*Prices given in **bold** figures refer to products on stock. Discount and delivery terms for other product assortment are given at request.

\*Die separat gekennzeichneten Prices ( **bold** ) beziehen sich auf die Ware, die auf Lager liegt. Die Rabatte und Lieferzeiten für das restliche Sortiment geben wir auf Anfrage bekannt.

**UPUŠTAČI KUPASTI 90°, VALJKASTA DRŠKA**

**COUNTERSINKS 90°, STRAIGHT SHANK**

**KEGELSENKER 90°, ZYLINDERSCHAFT**

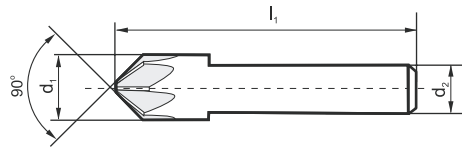

Series				SU21	SU22
Material				HSS	CO 5%
Type				A	A
Number of flute				5-7	5-7
	d <sub>1</sub>	l <sub>1</sub>	d <sub>2</sub>	price EUR	
	mm	mm	mm	each	each
00800	8	48	8	11,200	15,680
01250	12,5	48	8	15,064	21,084
01600	16	56	10	17,080	23,912
02000	20	60	10	24,500	34,300

**UPUŠTAČI KUPASTI 90°, MK DRŠKA**

**COUNTERSINKS 90°, MORSE TAPER SHANK**

**KEGELSENKER 90°, MORSEKEGELSCHAFT**

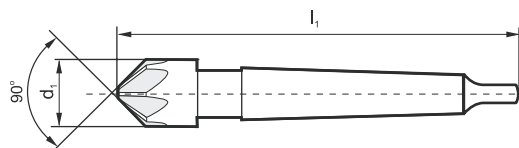

Series				SU23	SU24
Material				HSS	CO 5%
Type				B	B
Number of flute				6-18	6-18
	d <sub>1</sub>	l <sub>1</sub>	MT	price EUR	
	mm	mm		each	each
01600	16	95	1	26,600	33,250
02500	25	118	2	36,582	45,724
03150	31,5	122	2	59,850	74,816
04000	40	150	3	119,700	149,632
05000	50	155	3	194,180	242,732
06300	63	185	4	335,160	418,950
08000	80	196	4	614,460	768,082

\*Posebno označene cijene ( **bold** ) odnose se na robu koju imamo na lageru. Za ostali asortiman rabate i rokove isporuke dajemo na osnovu upita.

\*Prices given in **bold** figures refer to products on stock. Discount and delivery terms for other product assortment are given at request.

\*Die separat gekennzeichneten Prices ( **bold** ) beziehen sich auf die Ware, die auf Lager liegt. Die Rabatte und Lieferzeiten für das restliche Sortiment geben wir auf Anfrage bekannt.

UPUŠTAČI KUPASTI 90°, VALJKASTA DRŠKA

COUNTERSINKS 90°, STRAIGHT SHANK

KEGELSENKER 90°, ZYLINDERSCHAFT

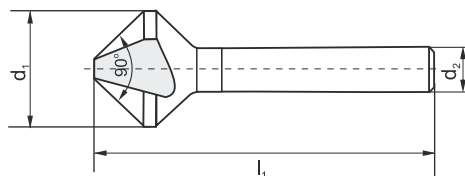

Series				SU25	SU26
	Material			HSS	CO 5%
	Type			C	C
	Number of flute			3	3
	d <sub>1</sub>	l <sub>1</sub>	d <sub>2</sub>	price EUR	
	mm	mm	mm	each	each
00430	4.3	40	4	<b>8,400</b>	11,760
00500	5	40	4	8,400	11,760
00530	5.3	40	4	<b>8,400</b>	11,760
00580	5.8	45	5	8,400	11,760
00600	6	45	5	8,400	11,760
00630	6.3	45	5	<b>8,400</b>	11,760
00700	7	50	6	9,240	12,936
00730	7.3	50	6	9,660	13,524
00800	8	50	6	9,800	13,720
00830	8.3	50	6	<b>9,800</b>	13,720
00940	9.4	50	6	10,920	15,288
01000	10	50	6	12,040	16,856
01040	10.4	50	6	<b>12,320</b>	17,248
01150	11.5	56	8	13,580	19,012
01240	12.4	56	8	<b>13,720</b>	19,208
01340	13.4	56	8	14,000	19,600
01500	15	60	10	14,840	20,776
01650	16.5	60	10	<b>16,100</b>	22,540
01900	19	63	10	21,700	30,380
02050	20.5	63	10	<b>22,400</b>	31,360
02300	23	67	10	33,600	47,040
02500	25	67	10	<b>36,400</b>	50,960
02600	26	67	10	42,000	58,800
02800	28	71	12	49,000	68,600
03000	30	71	12	50,400	70,560
03100	31	71	12	<b>51,800</b>	72,520

\*Posebno označene cijene ( **bold** ) odnose se na robu koju imamo na lageru. Za ostali asortiman rabate i rokove isporuke dajemo na osnovu upita.

\*Prices given in **bold** figures refer to products on stock. Discount and delivery terms for other product assortment are given at request.

\*Die separat gekennzeichneten Prices ( **bold** ) beziehen sich auf die Ware, die auf Lager liegt. Die Rabatte und Lieferzeiten für das restliche Sortiment geben wir auf Anfrage bekannt.

UPUŠTAČI KUPASTI 90°, MK DRŠKA

COUNTERSINKS 90°, MORSE TAPER SHANK

KEGELSENKER 90°, MORSEKEGELSCHAFT

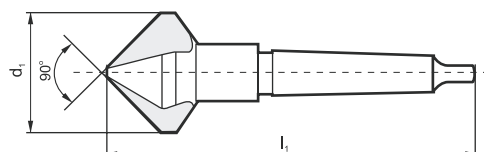

Series				SU27	SU28
	Material				HSS
Type				D	D
Number of flute				3	3
	d <sub>1</sub>	l <sub>1</sub>	MT	price EUR	
	mm	mm		each	each
01500	15	85	1	20,160	25,200
01650	16.5	85	1	23,240	29,050
01900	19	100	2	27,300	34,132
02050	20.5	100	2	28,000	35,000
02300	23	106	2	29,400	36,750
02500	25	106	2	38,780	48,482
02600	26	106	2	38,780	48,482
02800	28	112	2	47,600	59,500
03000	30	112	2	<b>51,380</b>	64,232
03100	31	113	2	<b>56,000</b>	70,000
03400	34	118	2	63,700	79,632
03700	37	118	2	<b>71,400</b>	89,250
04000	40	140	3	<b>99,400</b>	124,250
05000	50	150	3	<b>161,000</b>	201,250
06300	63	180	4	<b>280,000</b>	350,000
08000	80	190	4	520,800	651,000

\*Posebno označene cijene ( **bold** ) odnose se na robu koju imamo na lageru. Za ostali asortiman rabate i rokove isporuke dajemo na osnovu upita.

\*Prices given in **bold** figures refer to products on stock. Discount and delivery terms for other product assortment are given at request.

\*Die separat gekennzeichneten Prices ( **bold** ) beziehen sich auf die Ware, die auf Lager liegt. Die Rabatte und Lieferzeiten für das restliche Sortiment geben wir auf Anfrage bekannt.



**UPUŠTAČI KUPASTI 120°, VALJKASTA DRŠKA**

**COUNTERSINKS 120°, STRAIGHT SHANK**

**KEGELSENKER 120°, ZYLINDERSCHAFT**

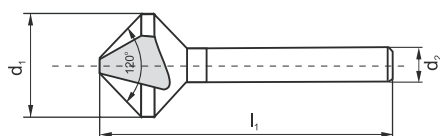

Series				SU31	SU32
Material				HSS	CO 5%
Type				C	C
Number of flute				3	3
	d <sub>1</sub>	l <sub>1</sub>	d <sub>2</sub>	price EUR	
	mm	mm	mm	each	each
00630	6.3	45	5	9,800	13,720
00830	8.3	50	6	11,508	16,114
01040	10.4	50	6	13,720	19,208
01240	12.4	56	8	15,400	21,560
01600	16	60	10	18,200	25,480
01650	16.5	60	10	18,480	25,872
02050	20.5	63	10	26,320	36,848
02500	25	67	10	46,900	65,660

**UPUŠTAČI KUPASTI 120°, MK DRŠKA**

**COUNTERSINKS 120°, MORSE TAPER SHANK**

**KEGELSENKER 120°, MORSEKEGELSCHAFT**

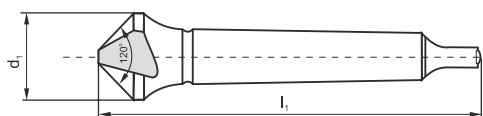

Series				SU33	SU34
Material				HSS	CO 5%
Type				D	D
Number of flute				3	3
	d <sub>1</sub>	l <sub>1</sub>	MT	price EUR	
	mm	mm		each	each
01650	16.5	86	1	28,420	35,532
02050	20.5	103	2	35,560	44,450
02500	25	112	2	38,500	48,132
03100	31	117	2	63,280	79,100
04000	40	140	3	127,400	159,250

\*Posebno označene cijene ( **bold** ) odnose se na robu koju imamo na lageru. Za ostali asortiman rabate i rokove isporuke dajemo na osnovu upita.

\*Prices given in **bold** figures refer to products on stock. Discount and delivery terms for other product assortment are given at request.

\*Die separat gekennzeichneten Prices ( **bold** ) beziehen sich auf die Ware, die auf Lager liegt. Die Rabatte und Lieferzeiten für das restliche Sortiment geben wir auf Anfrage bekannt.

**GLATKE BURGIJE ZA LIM**

**SHEET AND TUBE DRILLS**

**BLECHSCHÄLBOHRER**

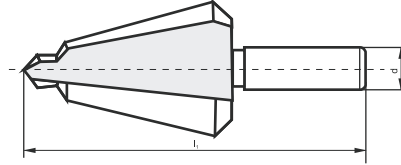

Series	Material				SU51	SU52
	N <sub>0</sub>	min-max mm	l <sub>1</sub> mm	d mm	HSS	Co 5%
					price EUR	
					each	each
NO001	1	3-14	58	6	<b>11,060</b>	13,832
NO002	2	6-20	63	8	<b>19,320</b>	24,150
NO003	3	16-30	72	10	<b>39,200</b>	49,000
NO004	4	26-40	86	10	84,000	105,000
NO005	5	35-50	89	12	126,000	157,500
NO006	6	46-60	90	12	210,000	262,500
NO007	7	3-22,5	73	8	48,020	60,032
NO008	8	3-31	102	10	66,080	82,600

**STEPENASTE BURGIJE ZA LIM**

**STEP DRILLS FOR SHEET**

**STUFENBOHRER FÜR BLECHE**

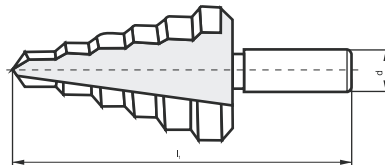

Series	Material						SU55	SU56
	N <sub>0</sub>	min-max mm	steps mm	steps number	l <sub>1</sub> mm	d mm	price EUR	
							HSS	Co 5%
							each	each
N0001	1	4-12	2	5	55	6	23,800	29,750
N0002	2	4-12	1	9	70	6	<b>25,200</b>	31,500
N0003	3	12-20	1	9	85	10	67,200	84,000
N0004	4	4-20	2	9	85	10	<b>35,560</b>	44,450
N0005	5	20-30	1	11	97	13	114,800	143,500
N0006	6	4-30	2	14	96	10	<b>77,000</b>	96,250
N0007	7	30-40	1	11	97	13	159,600	199,500
N0008	8	40-50	1	11	100	13	226,800	283,500
N0009	9	6,3-26,75		7	90	13	99,400	124,250
N0010	10	6,3-38		11	96	13	<b>126,000</b>	157,500

\*Posebno označene cijene ( **bold** ) odnose se na robu koju imamo na lageru. Za ostali asortiman rabate i rokove isporuke dajemo na osnovu upita.

\*Prices given in **bold** figures refer to products on stock. Discount and delivery terms for other product assortment are given at request.

\*Die separat gekennzeichneten Prices ( **bold** ) beziehen sich auf die Ware, die auf Lager liegt. Die Rabatte und Lieferzeiten für das restliche Sortiment geben wir auf Anfrage bekannt.

**SPECIJALNE BURGJE**

**SPECIAL DRILLS**

**SPEZIALBOHRER**

**BURGIJA ZA VAR, KRATKA**

**SPOTLE DRILLS**

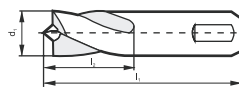

Series	Material				SU63	SU64
					HSS	Co 5%
	d <sub>1</sub>	d <sub>2</sub>	l <sub>1</sub>	l <sub>2</sub>	price EUR	
	mm	mm	mm	mm	each	each
00650	6,5	6,5	40	18	4,032	<b>5,040</b>
00800	8	8	40	18	4,928	<b>6,160</b>
00800	8	8	44	18	5,152	6,440
00658	6,5	8	44	18	5,668	7,084

**BURGIJA ZA VAR**

**FAST CUT**

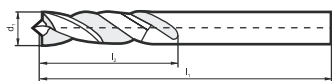

Series	Material			SU65	SU66
				HSS	Co 5%
	d <sub>1</sub>	l <sub>1</sub>	l <sub>2</sub>	price EUR	
	mm	mm	mm	each	each
00600	6	65	28	4,032	<b>4,844</b>
00700	7	75	35	4,928	5,908
00800	8	80	38	5,152	6,188
01000	10	90	45	6,300	7,560

**BURGIJA - GLODALO**

**MILLING DRILLS**

**FRÄSBOHRER**

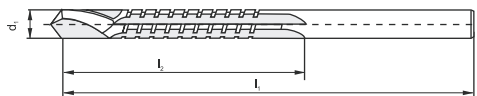

Series	Material			SU67	SU68
				HSS	Co 5%
	d <sub>1</sub>	l <sub>1</sub>	l <sub>2</sub>	price EUR	
	mm	mm	mm	each	each
00600	6	90	60	9,100	10,920
00800	8	90	60	10,080	12,096

\*Posebno označene cijene ( **bold** ) odnose se na robu koju imamo na lageru. Za ostali asortiman rabate i rokove isporuke dajemo na osnovu upita.

\*Prices given in **bold** figures refer to products on stock. Discount and delivery terms for other product assortment are given at request.

\*Die separat gekennzeichneten Prices ( **bold** ) beziehen sich auf die Ware, die auf Lager liegt. Die Rabatte und Lieferzeiten für das restliche Sortiment geben wir auf Anfrage bekannt.

NASADNI UPUŠTAČI SA KONUSOM 1:30

SHELL DRILL WITH TAPER 1:30

AUFSTECK - AUFBOHRER MIT KEGELBOHRUNG 1:30

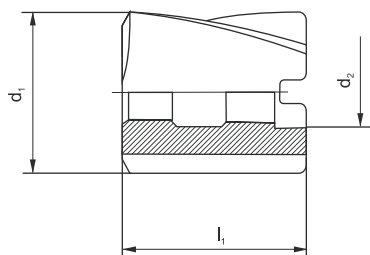

Series	Material			SU71	SU72
				HSS	Co 5%
	d <sub>1</sub>	l <sub>1</sub>	d <sub>2</sub>	price EUR	
	mm	mm	mm	each	each
03000	30	45	13	60,800	85,120
03100	31	45	13	68,000	95,200
03200	32	45	13	62,400	87,360
03300	33	45	13	74,400	104,160
03400	34	45	13	75,200	105,280
03500	35	45	13	62,400	87,360
03600	36	50	16	64,000	89,600
03700	37	50	16	80,000	112,000
03800	38	50	16	68,800	96,320
04000	40	50	16	69,600	97,440
04200	42	50	16	70,400	98,560
04400	44	50	16	83,200	116,480
04500	45	50	16	76,000	106,400
04600	46	56	19	98,400	137,760
04700	47	56	19	108,000	151,200
04800	48	56	19	104,000	145,600
05000	50	56	19	88,800	124,320
05200	52	56	19	93,600	131,040
05500	55	63	22	110,400	154,560
05800	58	63	22	119,200	166,880
06000	60	63	22	120,000	168,000
06200	62	63	22	134,400	188,160
06500	65	71	27	164,000	229,600
07000	70	71	27	164,000	229,600
07200	72	71	27	192,800	269,920
07500	75	71	27	193,600	271,040

\*Posebno označene cijene ( **bold** ) odnose se na robu koju imamo na lageru. Za ostali asortiman rabate i rokove isporuke dajemo na osnovu upita.

\*Prices given in **bold** figures refer to products on stock. Discount and delivery terms for other product assortment are given at request.

\*Die separat gekennzeichneten Prices ( **bold** ) beziehen sich auf die Ware, die auf Lager liegt. Die Rabatte und Lieferzeiten für das restliche Sortiment geben wir auf Anfrage bekannt.

**REDUCIR ČAURE, POTPUNO KALJENE, BRUŠENE**

**TAPER SLEEVES, HARDENED AND GROUND**

**REDUZIERSHÜLSEN GANZ GEHARTETUND GESCHLIFFEN**

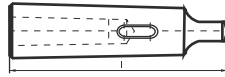

Series	Finish			SP01
	MT	MT	l	ground
	External	Internal	mm	price EUR
01000	1	0	85	19,200
02001	2	1	92	19,200
03001	3	1	99	22,400
03002	3	2	112	23,360
04001	4	1	124	31,200
04002	4	2	124	28,480
04003	4	3	140	28,000
05002	5	2	156	43,520
05003	5	3	156	47,200
05004	5	4	171	47,200
06003	6	3	218	92,800
06004	6	4	218	93,760
06005	6	5	218	95,200

**DIN 2187**

**REDUCIR ČAURE, PRODUŽENE, POTPUNO KALJENE, BRUŠENE**

**EXTENSION TAPER SLEEVES HARDENED AND GROUND**

**VERLANGERUNGSHÜLSEN GANZ GEHÄRTETUND GESCHLIFFEN**

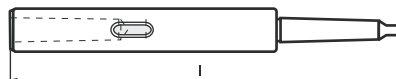

Series	Finish			SP02
	MT	MT	l	ground
	External	Internal	mm	price EUR
01001	1	1	145	28,480
01002	1	2	160	30,240
02001	2	1	160	22,880
02002	2	2	170	29,600
02003	2	3	200	38,080
03002	3	2	195	29,600
03003	3	3	215	42,240
03004	3	4	240	65,120
04002	4	2	215	42,240
04003	4	3	240	49,280
04004	4	4	265	65,120
04005	4	5	300	128,000
05002	5	2	250	144,000
05003	5	3	268	63,360
05004	5	4	300	68,640
05005	5	5	335	130,560
05006	5	6	396	228,800
06003	6	3	330	130,240
06004	6	4	355	130,240
06005	6	5	390	131,200
06006	6	6	451	228,800

IZBIJAČ ALATA

EJECTOR DRIFTS

AUSTREIBER FÜR WERKZEUGKEGEL

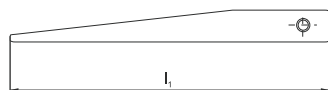

Series	SP08		
	Finish		ground
	Size	price EUR	
		l <sub>1</sub>	each
		mm	
00000	0	90	4,160
00102	1 - 2	140	7,520
00003	3	190	11,680
00004	4	225	17,600
00506	5 - 6	265	23,200

DIN 238

TRNOVI ZA STEZNE GLAVE

TAPER DRILL CHUCK ARBORS

KEGELDORNE FÜR BOHRFUTER

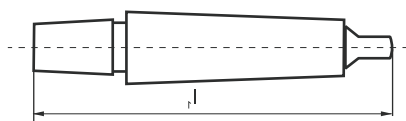

Series	SP05			
	Finish		ground	
	MT	Drill Chuck Taper	price EUR	
			l <sub>1</sub>	each
			mm	
01010	1	B 10	86	8,160
01012	1	B 12	89	8,160
01016	1	B 16	99	9,120
01018	1	B 18	107	10,400
02010	2	B 10	105	10,720
02012	2	B 12	106	10,720
02016	2	B 16	112	10,720
02018	2	B 18	119	12,000
02022	2	B 22	130	14,080
03012	3	B 12	127	16,160
03016	3	B 16	134	16,160
03018	3	B 18	140	16,160
03022	3	B 22	147	16,160
03024	3	B 24	157	17,600
04016	4	B 16	158	24,480
04018	4	B 18	166	24,960
04022	4	B 22	176	25,760
04024	4	B 24	186	26,240
05016	5	B 16	193	43,680
05018	5	B 18	200	45,280
05022	5	B 22	208	47,360
05024	5	B 24	221	49,600

\*Posebno označene cijene ( **bold** ) odnose se na robu koju imamo na lageru. Za ostali asortiman rabate i rokove isporuke dajemo na osnovu upita.

\*Prices given in **bold** figures refer to products on stock. Discount and delivery terms for other product assortment are given at request.

\*Die separat gekennzeichneten Prices ( **bold** ) beziehen sich auf die Ware, die auf Lager liegt. Die Rabatte und Lieferzeiten für das restliche Sortiment geben wir auf Anfrage bekannt.



**NOŽEVI PRAVOUGLI (D)**

**RECTANGULAR TOOL BITS**

**RECHTECKIGE DREHLINGE**



Series	SN21		SN22		SN23		SN24		SN25		SN26	
	Material	Co 8-10%	Co 8-10%	Co 8-10%	Co 8-10%	Co 8-10%	Co 8-10%	Co 8-10%	Co 8-10%	Co 8-10%	Co 8-10%	Co 8-10%
	Lenght	80	100	125	160	200	250					
Size (h14/h14)	price EUR											
	each	each	each	each	each	each	each	each	each	each	each	each
06004	6x4	4,960	6,720									
08004	8x4	5,440	6,880			11,200						
08005	8x5	6,720	8,320									
10005	10x5	8,640	11,680			18,080	21,760					
10006	10x6		12,800	13,760	21,760	26,880						
12006	12x6		14,880		23,200	27,520						
12008	12x8		16,640	24,960	27,680	33,952						
16004	16x4	11,680	14,560		23,520							
16008	16x8		21,600		32,640	39,680						
16010	16x10		25,600	33,600	43,680	53,280						
20005	20x5		20,000		32,000	39,840						
20010	20x10		29,920		48,000	59,680	75,200					
20012	20x12		30,720	40,000	52,960	65,920						
25006	25x6		24,640		37,760	45,760						
25012	25x12				69,120	86,400	107,840					
25016	25x16		47,200	62,080	82,720	103,840	129,920					
32008	32x8		42,240		63,840	77,120						
32016	32x16				123,680	154,720						
40010	40x10				97,760	122,080						

**NOŽEVI TRAPEZNI (E)**

**TRAPEZOIDAL TOOL BITS**

**TRAPEZFÖRMIGE DREHLINGE**



Series	SN31		SN32		SN33		SN34		SN35		SN36	
	Material	Co 8-10%	Co 8-10%	Co 8-10%	Co 8-10%	Co 8-10%	Co 8-10%	Co 8-10%	Co 8-10%	Co 8-10%	Co 8-10%	Co 8-10%
	Lenght	80	100	125	160	200	250					
Size (h12/h12)	price EUR											
	each	each	each	each	each	each	each	each	each	each	each	each
12003	12x3	7,680	9,920	13,280	15,680	23,200						
16004	16x4	15,840	19,200	20,160	31,680	39,360						
20005	20x5	19,680	24,640	30,240	39,840	55,040						
25006	25x6		29,920	38,720	48,480	60,800	76,000					

\*Posebno označene cijene ( **bold** ) odnose se na robu koju imamo na lageru. Za ostali asortiman rabate i rokove isporuke dajemo na osnovu upita.

\*Prices given in **bold** figures refer to products on stock. Discount and delivery terms for other product assortment are given at request.

\*Die separat gekennzeichneten Prices ( **bold** ) beziehen sich auf die Ware, die auf Lager liegt. Die Rabatte und Lieferzeiten für das restliche Sortiment geben wir auf Anfrage bekannt.

**NOŽEVI OKRUGLI (A)**

**REOUND TOOL BITS**

**RUNDE DREHLINGE**



Series		SN01	SN02	SN03	SN04	SN05	SN06	SN07
	Material	Co 8-10%	Co 8-10%	Co 8-10%	Co 8-10%	Co 8-10%	Co 8-10%	Co 8-10%
	Lenght	40	63	80	100	125	160	200
	Size (h14)	price EUR						
		each	each	each	each	each	each	each
00400	4	2,400	3,520	4,320				
00500	5	2,720	3,520	4,320				
00600	6	2,880	3,840	4,960	6,400	7,680	9,280	11,200
00800	8	3,520	5,280	7,040	8,800	13,280	14,080	16,000
01000	10	4,960	8,480	9,760	13,440	16,960	25,120	31,040
01200	12		9,760	12,800	14,080	21,600	32,320	40,160
01400	14					28,320	38,880	56,000
01600	16				24,640	28,320	38,880	56,000
01800	18						75,040	108,000
02000	20				36,960	52,320	87,200	108,800

**NOŽEVI KVADRATNI (B)**

**SQUARE TOOL BITS**

**QUADRATISCHE DREHLINGE**



Series		SN11	SN12	SN13	SN14	SN15	SN16	SN17	SN18
	Material	Co 8-10%	Co 8-10%	Co 8-10%	Co 8-10%	Co 8-10%	Co 8-10%	Co 8-10%	Co 8-10%
	Lenght	40	63	80	100	125	160	200	250
	Size (h14)	price EUR							
		each	each	each	each	each	each	each	each
00400	4x4	2,720	3,360	4,640					
00500	5x5	3,200	5,280	6,400					
00600	6x6	2,880	4,640	5,920	7,360	9,120	11,840	14,720	
00800	8x8	5,440	6,400	8,160	10,240	15,200	16,320	20,800	
01000	10x10		10,240	12,800	17,280	21,760	28,320	36,320	
01200	12x12		13,760	18,240	21,760	28,320	36,800	47,200	
01400	14x14				26,720	32,480	43,680	52,640	
01600	16x16				34,720	54,240	59,360	77,120	
01800	18x18						72,480	90,880	
02000	20x20						92,160	117,120	144,000
02500	25x25						147,040	183,520	228,480

\*Posebno označene cijene ( **bold** ) odnose se na robu koju imamo na lageru. Za ostali asortiman rabate i rokove isporuke dajemo na osnovu upita.

\*Prices given in **bold** figures refer to products on stock. Discount and delivery terms for other product assortment are given at request.

\*Die separat gekennzeichneten Prices ( **bold** ) beziehen sich auf die Ware, die auf Lager liegt. Die Rabatte und Lieferzeiten für das restliche Sortiment geben wir auf Anfrage bekannt.

**UGAONA GLODALA, JEDNOSTRANA**

**ANGULAR CUTTERS WITH PLAIN BORE**

**AUFSTECK - WINKELSTIRNFRÄSER**

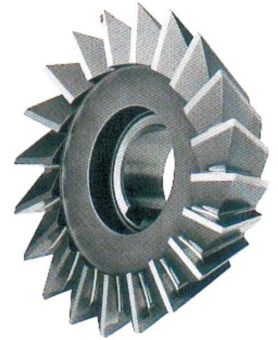
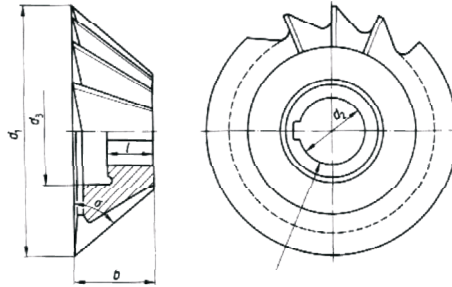

Series							SG101	SG102
	Material						HSS	Co 5%
	Type						A	A
	$\beta$	$d_1$	b	$d_2$	$d_3$	l	price EUR	
		js16	js14	H7	js15	js14	each	each
045040	45°	40	10	10	15	5,5	46,800	58,500
045050	45°	50	13	13	19	7,5	49,200	61,500
045063	45°	63	18	16	23	12	75,400	94,250
045080	45°	80	22	22	30	14	111,600	139,500
045100	45°	100	28	27	39	17	165,600	207,000
045125	45°	125	36	32	46	24	253,200	316,500
045160	45°	160	45	40	56	31	450,000	562,500
050040	50°	40	13	10	15	8	50,000	62,500
050050	50°	50	16	13	19	10	53,400	66,750
050063	50°	63	20	16	23	12	82,000	102,500
050080	50°	80	25	22	30	14	119,200	149,000
050100	50°	100	32	27	39	17	176,800	221,000
050125	50°	125	40	32	46	24	270,000	337,500
050160	50°	160	50	40	56	31	480,000	600,000
055040	55°	40	13	10	15	8	50,000	62,500
055050	55°	50	16	13	19	10	53,400	66,750
055063	55°	63	20	16	23	12	82,000	102,500
055080	55°	80	25	22	30	14	119,200	149,000
055100	55°	100	32	27	39	17	176,800	221,000
055125	55°	125	40	32	46	24	270,000	337,500
055160	55°	160	50	40	56	31	480,000	600,000
060040	60°	40	13	10	15	8	50,000	62,500
060050	60°	50	16	13	19	10	53,400	66,750
060063	60°	63	20	16	23	12	82,000	102,500
060080	60°	80	25	22	30	14	119,200	149,000
060100	60°	100	32	27	39	17	176,800	221,000
060125	60°	125	40	32	46	24	270,000	337,500
060160	60°	160	50	40	56	31	480,000	600,000

\*Posebno označene cijene ( **bold** ) odnose se na robu koju imamo na lageru. Za ostali asortiman rabate i rokove isporuke dajemo na osnovu upita.

\*Prices given in **bold** figures refer to products on stock. Discount and delivery terms for other product assortment are given at request.

\*Die separat gekennzeichneten Prices ( **bold** ) beziehen sich auf die Ware, die auf Lager liegt. Die Rabatte und Lieferzeiten für das restliche Sortiment geben wir auf Anfrage bekannt.

**UGAONA GLODALA, SIMETRIČNA**

**DOUBLE EQUAL - ANGULAR CUTTERS**

**PRISMENFRÄSER**

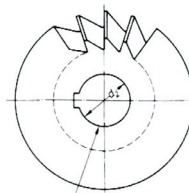
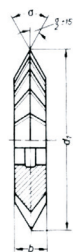

Series					SG103	SG104
	Material				HSS	Co 5%
	Type				A	A
	b	d <sub>1</sub>	b	d <sub>2</sub>	price EUR	
	± 30'	js16	js16	H7	each	each
045050	45°	50	8	16	54,400	68,000
045063	45°	63	10	22	58,320	72,900
045080	45°	80	12	27	86,000	107,500
045100	45°	100	18	32	128,640	160,800
060050	60°	50	10	16	59,600	74,500
060063	60°	63	14	22	67,600	84,500
060080	60°	80	18	27	106,960	133,700
060100	60°	100	25	32	186,920	233,650
090050	90°	50	14	16	72,800	91,000
090063	90°	63	20	22	80,640	100,800
090080	90°	80	22	27	119,640	149,550
090100	90°	100	32	32	224,160	280,200

**DIN 855**

**POLUKRUŽNA UDUBLJENA GLODALA**

**CONCAVE MILLING CUTTERS**

**HALBROUND - PROFILFRÄSER (KONKAV)**

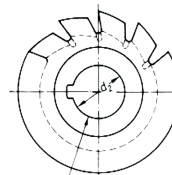
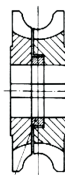
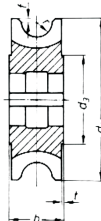

Series								SG105	SG106
	Material							HSS	Co 5%
	Form							A	A
	r	d <sub>1</sub>	d <sub>2</sub>	d <sub>3</sub>	b	f	t	price EUR	
	H11	js16	H7		mm			each	each
100059	1	50	16		6	0,2		35,200	44,000
125050	1,25	50	16		6	0,2		35,600	44,500
160050	1,6	50	16		8	0,25		39,600	49,500
200050	2	50	16		9	0,25		42,000	52,500
250063	2,5	63	22		10	0,3		52,800	66,000
300063	3	63	22		12	0,3		59,600	74,500
315063	3,15	63	22		12	0,3		60,800	76,000
400063	4	63	22		16	0,4		72,800	91,000
500063	5	63	22		20	0,5		82,800	103,500
600080	6	80	27	41	24	0,6	0,5	126,800	158,500
630080	6,3	80	27	41	24	0,6	0,5	131,200	164,000
800080	8	80	27	41	32	0,8	0,5	163,600	204,500
100100	10	100	32	47	36	1	0,5	258,400	323,000
120100	12	100	32	47	40	1,2	0,5	290,800	363,500
125100	12,5	100	32	47	40	1,2	0,5	294,000	367,500
160125	16	125	32	47	50	1,6	0,5	504,000	630,000
200125	20	125	32	47	60	2	0,5	596,000	745,000

**POLUKRUŽNA ISPUPČENA GLODALA**

**CONVEX MILLING CUTTERS**

**HALBROUND - PROFILFRÄSER, KONVEX**

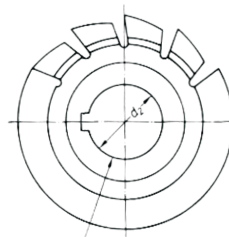
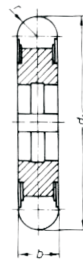

Series	Material				SG107	SG108
					HSS	Co 5%
	r	d <sub>1</sub>	d <sub>2</sub>	b	price EUR	
	h11	js16	H7		each	each
100050	1	50	16	2	23,000	28,750
125050	1,25	50	16	2,5	24,880	31,100
160050	1,6	50	16	3,2	26,000	32,500
200050	2	50	16	4	26,400	33,000
250050	2,5	63	22	5	31,400	39,250
300063	3	63	22	6	33,760	42,200
315063	3,15	63	22	6,3	40,640	50,800
400063	4	63	22	8	44,200	55,250
500063	5	63	22	10	51,480	64,350
600080	6	80	27	12	67,640	84,550
630080	6,3	80	27	12,6	69,840	87,300
800080	8	80	27	16	82,000	102,500
100100	10	100	32	20	134,320	167,900
120100	12	100	32	24	156,200	195,250
125100	12,5	100	32	25	176,000	220,000
160125	16	125	32	32	270,400	338,000
200125	20	125	32	40	402,000	502,500

DIN 884

**VALJKASTA GLODALA**

**SOLID CYLINDRICAL CUTTERS**

**WÄLZENFRASER**

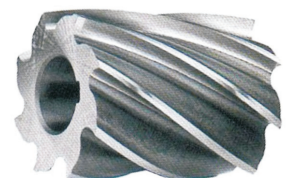
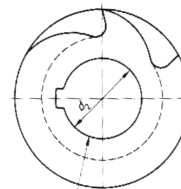
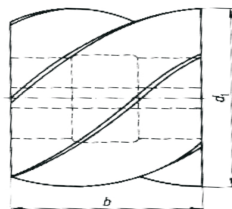

Series	Material			SG109	SG110
				HSS	Co 5%
	d <sub>1</sub>	b	d <sub>2</sub>	price EUR	
	js16	js16	H7	each	each
050040	50	40	22	85,400	106,750
050063	50	63	22	126,720	158,400
050080	50	80	22	156,520	195,650
063050	63	50	27	145,200	181,500
063070	63	70	27	193,840	242,300
080063	80	63	32	273,080	341,350
080100	80	100	32	394,000	492,500
100070	100	70	40	407,200	509,000

\*Posebno označene cijene ( **bold** ) odnose se na robu koju imamo na lageru. Za ostali asortiman rabate i rokove isporuke dajemo na osnovu upita.

\*Prices given in **bold** figures refer to products on stock. Discount and delivery terms for other product assortment are given at request.

\*Die separat gekennzeichneten Prices ( **bold** ) beziehen sich auf die Ware, die auf Lager liegt. Die Rabatte und Lieferzeiten für das restliche Sortiment geben wir auf Anfrage bekannt.



**KOTURASTA GLODALA**

**SIDE AND FACE MILLING CUTTERS**

**SCHEIBENFRÄSER**

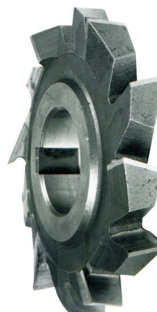
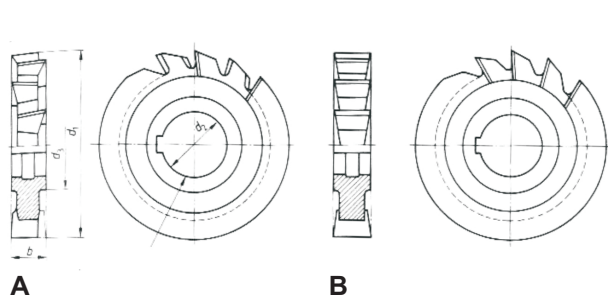

Series						SG111	SG112	SG113	SG114
	Material					HSS	Co 5%	HSS	Co 5%
	Type					A	A	B	B
	d <sub>1</sub>	b	d <sub>2</sub>	d <sub>3</sub>	z	price EUR			
js16	k11	H7	mm		each	each	each	each	
050004	50	4	16	27	12	42,800	53,500	42,800	53,500
050005	50	5	16	27	12	43,600	54,500	43,600	54,500
050006	50	6	16	27	12	45,600	57,000	45,600	57,000
050008	50	8	16	27	12	49,200	61,500	49,200	61,500
050010	50	10	16	27	12	52,800	66,000	52,800	66,000
063004	63	4	22	34	12	47,600	59,500	47,600	59,500
063005	63	5	22	34	12	47,600	59,500	47,600	59,500
063006	63	6	22	34	12	48,800	61,000	48,800	61,000
063008	63	8	22	34	12	56,800	71,000	56,800	71,000
063010	63	10	22	34	12	60,800	76,000	60,800	76,000
063012	63	12	22	34	12	66,800	83,500	66,800	83,500
063014	63	14	22	34	12	72,000	90,000	72,000	90,000
063016	63	16	22	34	12	78,400	98,000	78,400	98,000
080005	80	5	27	41	14	62,800	78,500	62,800	78,500
080006	80	6	27	41	14	66,400	83,000	66,400	83,000
080008	80	8	27	41	14	72,800	91,000	72,800	91,000
080010	80	10	27	41	14	79,600	99,500	79,600	99,500
080012	80	12	27	41	14	91,200	114,000	91,200	114,000
080014	80	14	27	41	14	96,800	121,000	96,800	121,000
080016	80	16	27	41	14	106,000	132,500	106,000	132,500
080018	80	18	27	41	14	114,000	142,500	114,000	142,500
080020	80	20	27	41	14	121,600	152,000	121,600	152,000
100006	100	6	32	47	16	88,000	110,000	88,000	110,000
100008	100	8	32	47	16	100,000	125,000	100,000	125,000
100010	100	10	32	47	16	116,000	145,000	116,000	145,000
100012	100	12	32	47	16	129,600	162,000	129,600	162,000
100014	100	14	32	47	16	143,200	179,000	143,200	179,000
100016	100	16	32	47	16	149,200	186,500	149,200	186,500
100018	100	18	32	47	16	160,800	201,000	160,800	201,000
100020	100	20	32	47	16	167,600	209,500	167,600	209,500
100022	100	22	32	47	16	182,800	228,500	182,800	228,500
100025	100	25	32	47	16	197,200	246,500	197,200	246,500

\*Posebno označene cijene ( **bold** ) odnose se na robu koju imamo na lageru. Za ostali asortiman rabate i rokove isporuke dajemo na osnovu upita.

\*Prices given in **bold** figures refer to products on stock. Discount and delivery terms for other product assortment are given at request.

\*Die separat gekennzeichneten Prices ( **bold** ) beziehen sich auf die Ware, die auf Lager liegt. Die Rabatte und Lieferzeiten für das restliche Sortiment geben wir auf Anfrage bekannt.



Series						SG111	SG112	SG113	SG114
	Material					HSS	Co 5%	HSS	Co 5%
	Type					A	A	B	B
	d <sub>1</sub>	b	d <sub>2</sub>	d <sub>3</sub>		price EUR			
js16	k11	H7	mm	z	each	each	each	each	
125008	125	8	32	47	18	134,400	168,000	134,400	168,000
125010	125	10	32	47	18	151,600	189,500	151,600	189,500
125012	125	12	32	47	18	169,600	212,000	169,600	212,000
125014	125	14	32	47	18	194,800	243,500	194,800	243,500
125016	125	16	32	47	18	210,400	263,000	210,400	263,000
125018	125	18	32	47	18	229,200	286,500	229,200	286,500
125020	125	20	32	47	18	246,400	308,000	246,400	308,000
125022	125	22	32	47	18	294,800	368,500	294,800	368,500
125025	125	25	32	47	18	299,600	374,500	299,600	374,500
125028	125	28	32	47	18	325,200	406,500	325,200	406,500
160010	160	10	40	55	22	307,200	384,000	307,200	384,000
160012	160	12	40	55	22	312,800	391,000	312,800	391,000
160014	160	14	40	55	22	319,600	399,500	319,600	399,500
160016	160	16	40	55	22	343,200	429,000	343,200	429,000
160018	160	18	40	55	22	366,000	457,500	366,000	457,500
160020	160	20	40	55	22	391,200	489,000	391,200	489,000
160022	160	22	40	55	22	428,800	536,000	428,800	536,000
160025	160	25	40	55	22	474,400	593,000	474,400	593,000
160028	160	28	40	55	22	519,600	649,500	519,600	649,500
160032	160	32	40	55	22	544,000	680,000	544,000	680,000
200012	200	12	40	55	24	509,200	636,500	509,200	636,500
200014	200	14	40	55	24	518,800	648,500	518,800	648,500
200016	200	16	40	55	24	530,000	662,500	530,000	662,500
200018	200	18	40	55	24	552,000	690,000	552,000	690,000
200020	200	20	40	55	24	580,000	725,000	580,000	725,000
200022	200	22	40	55	24	596,000	745,000	596,000	745,000
200025	200	25	40	55	24	698,000	872,500	698,000	872,500
200028	200	28	40	55	24	720,000	900,000	720,000	900,000
200032	200	32	40	55	24	896,000	1120,000	896,000	1120,000
200036	200	36	40	55	24	1260,000	1575,000	1260,000	1575,000
200040	200	40	40	55	24	1760,000	2200,000	1760,000	2200,000

\*Posebno označene cijene ( **bold** ) odnose se na robu koju imamo na lageru. Za ostali asortiman rabate i rokove isporuke dajemo na osnovu upita.

\*Prices given in **bold** figures refer to products on stock. Discount and delivery terms for other product assortment are given at request.

\*Die separat gekennzeichneten Prices ( **bold** ) beziehen sich auf die Ware, die auf Lager liegt. Die Rabatte und Lieferzeiten für das restliche Sortiment geben wir auf Anfrage bekannt.

**UGAONA GLODALA**

**ANGULAR CUTTERS FOR TOOL-MAKING**

**WINKELFRÄSER FÜR WERKZEUGE**

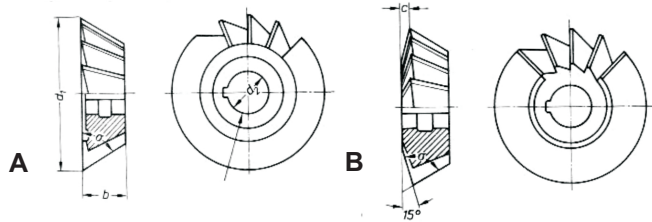

Series							SG115	SG116	SG117	SG118
	Material						HSS	Co 5%	HSS	Co 5%
	Type						A	A	B	B
	$\bar{b}$	$d_1$	b	c	$d_2$	price EUR				
	+1°	js16			H7	each	each	each	each	
060050	60°	50	12		16	50,400	63,000			
065050	65°	50	12		16	50,400	63,000			
075050	75°	50	12		16	50,400	63,000			
060063	60°	63	18		22	76,000	95,000			
070063	70°	63	18		22	76,000	95,000			
075063	75°	63	18		22	76,000	95,000			
080063	80°	63	18		22	76,000	95,000			
070050	70°	50	14	2	16			55,200	69,000	
075050	75°	50	16	2	16			55,200	69,000	
080050	80°	50	16	2	16			55,200	69,000	
060063	60°	63	14	3	22			79,200	99,000	
070063	70°	63	18	3	22			79,200	99,000	
075063	75°	63	18	3	22			79,200	99,000	
080063	80°	63	20	3	22			79,200	99,000	

**DIN 1824**

**UGAONA GLODALA ZA ŽLJEBOVE, SA PODSTRUGANIM ZUBIMA**

**TOOL-MAKING ANGULAR CUTTERS, FOR TOOLS WITH RELIEVED TEETH**

**LÜCKENFRÄSER FÜR WERKZEUGE**

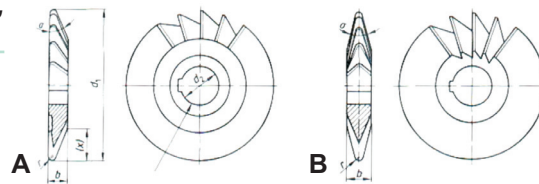

Series							SG119	SG120	SG121	SG122	
	Material						HSS	Co 5%	HSS	Co 5%	
	Type						A	A	B	B	
	$\bar{b}$	$d_1$	b	$d_2$	r	X≈	price EUR				
	+1°	js16	h12	H7	±0,1	Form A	Form B	each	each	each	each
018063	18°	63	5,6	16	1	11,9	11,9	47,600	59,500	44,800	56,000
018080	18°	80	9	22	1,25	21	21,1	75,200	94,000	71,600	89,500
018100	18°	100	11,2	22	1,6	25,9	26	113,600	142,000	108,000	135,000
024063	24°	63	7,1	16	1	12,2	12,3	51,600	64,500	49,200	61,500
024080	24°	80	11,2	22	1,25	20,5	20,6	80,800	101,000	76,800	96,000
024100	24°	100	14	22	1,6	25,5	25,6	123,200	154,000	117,200	146,500
030063	30°	63	8	16	1	11,1	11,1	53,600	67,000	51,600	64,500
030080	30°	80	12,5	22	1,25	18,2	18,3	85,600	107,000	81,200	101,500
030100	30°	100	18	22	1,6	26,8	26,9	144,000	180,000	137,600	172,000

**ČEONA NASADNA GLODALA  
SA POPREČNIM ŽLJEBOVIMA**

**SHELL END MILLS  
WITH TENON DRIVE**

**WALTZENSTIRNFRÄSER  
MIT QURENUT**

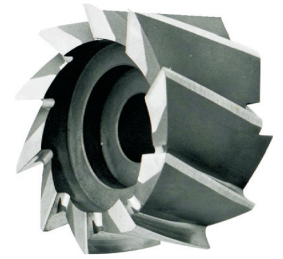
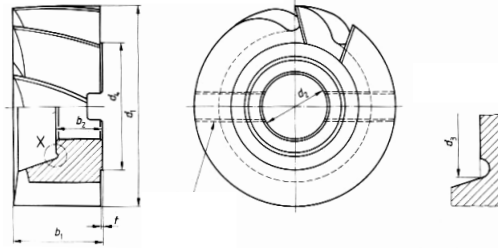

Series								SG123	SG124
Material								HSS	Co 5%
Form								N	N
								price EUR	
	d <sub>1</sub>	b <sub>1</sub>	b <sub>2</sub>	d <sub>2</sub>	d <sub>3</sub>	d <sub>4</sub>	t	each	each
	js16	k16	-1	H7	min.	min.	max.		
040032	40	32	19	16	23			58,800	73,500
050036	50	36	21	22	30			83,600	104,500
063040	63	40	23	27	38			124,000	155,000
080045	80	45	23	27	38	49	0,5	202,000	252,500
100050	100	50	26	32	45	59	0,5	322,000	402,500
125056	125	56	29	40	56	71	0,5	573,600	717,000
160063	160	63	32	50	67	91	0,5	990,000	1237,500

**ČEONA NASADNA GLODALA  
SA POPREČNIM ŽLJEBOVIMA, ZA TEŠKU OBRADU**

**SHELL END MILLS  
WITH TENON DRIVE, HEAVY-DUTY**

**WALTZENSTIRNFRÄSER  
MIT QURENUT FÜR SCHWERE BEARBEITUNG**

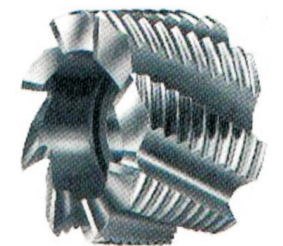
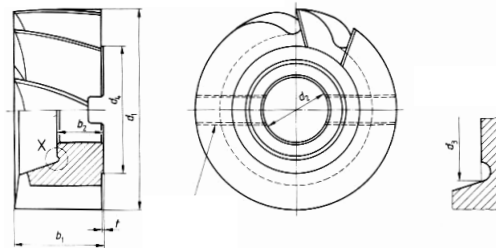

Series								SG125	SG126
Material								HSS	Co 5%
Form								F	F
								price EUR	
	d <sub>1</sub>	b <sub>1</sub>	b <sub>2</sub>	d <sub>2</sub>	d <sub>3</sub>	d <sub>4</sub>	t	each	each
	js16	k16	-1	H7	min.	min.	max.		
040032	40	32	19	16	23			68,800	86,000
050036	50	36	21	22	30			96,800	121,000
063040	63	40	23	27	38			141,600	177,000
080045	80	45	23	27	38	49	0,5	220,800	276,000
100050	100	50	26	32	45	59	0,5	343,200	429,000
125056	125	56	29	40	56	71	0,5	594,800	743,500
160063	160	63	32	50	67	91	0,5	1026,800	1283,500

\*Posebno označene cijene ( **bold** ) odnose se na robu koju imamo na lageru. Za ostali asortiman rabate i rokove isporuke dajemo na osnovu upita.

\*Prices given in **bold** figures refer to products on stock. Discount and delivery terms for other product assortment are given at request.

\*Die separat gekennzeichneten Prices ( **bold** ) beziehen sich auf die Ware, die auf Lager liegt. Die Rabatte und Lieferzeiten für das restliche Sortiment geben wir auf Anfrage bekannt.

ČEONA NASADNA GLODALA  
SA UZDUŽNIM ŽLJEBOVIMA

SHELL END MILLS  
WITH STANDARD KEYWAY

WALTZENSTIRNFRÄSER  
MIT LÄNGSNUT

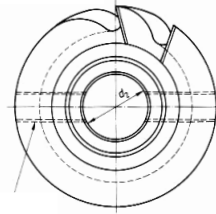
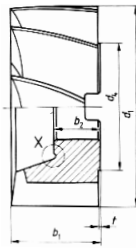

Series								SG127	SG128
	Material							HSS	Co 5%
	Form							N	N
	d <sub>1</sub>	b <sub>1</sub>	b <sub>2</sub>	d <sub>2</sub>	d <sub>3</sub>	d <sub>4</sub>	t	price EUR	
	js16	k16	-1	H7	min.	min.	max.	each	each
040032	40	32	19	16	23			57,200	71,500
050036	50	36	21	22	30			82,000	102,500
063040	63	40	23	27	38			124,000	155,000
080045	80	45	23	27	38	49	0,5	200,000	250,000
100050	100	50	26	32	45	59	0,5	320,000	400,000
125056	125	56	29	40	56	71	0,5	570,000	712,500
160063	160	63	32	50	67	91	0,5	986,000	1232,500

ČEONA NASADNA GLODALA  
SA UZDUŽNIM ŽLJEBOVIMA, ZA TEŠKU OBRADU

SHELL END MILLS  
WITH STANDARD KEYWAY, HEAVY-DUTY

WALTZENSTIRNFRÄSER  
MIT LÄNGSNUT FÜR SCHWERE BEARBEITUNG

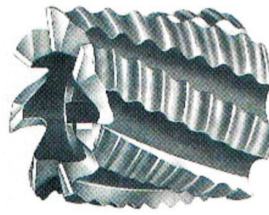
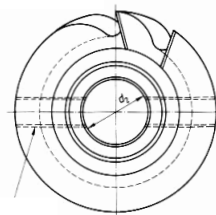
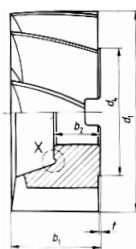

Series								SG129	SG130
	Material							HSS	Co 5%
	Form							F	F
	d <sub>1</sub>	b <sub>1</sub>	b <sub>2</sub>	d <sub>2</sub>	d <sub>3</sub>	d <sub>4</sub>	t	price EUR	
	js16	k16	-1	H7	min.	min.	max.	each	each
040032	40	32	19	16	23			67,600	84,500
050036	50	36	21	22	30			94,800	118,500
063040	63	40	23	27	38			140,000	175,000
080045	80	45	23	27	38	49	0,5	218,000	272,500
100050	100	50	26	32	45	59	0,5	340,800	426,000
125056	125	56	29	40	56	71	0,5	598,800	748,500
160063	160	63	32	50	67	91	0,5	1023,200	1279,000

\*Posebno označene cijene ( **bold** ) odnose se na robu koju imamo na lageru. Za ostali asortiman rabate i rokove isporuke dajemo na osnovu upita.

\*Prices given in **bold** figures refer to products on stock. Discount and delivery terms for other product assortment are given at request.

\*Die separat gekennzeichneten Prices ( **bold** ) beziehen sich auf die Ware, die auf Lager liegt. Die Rabatte und Lieferzeiten für das restliche Sortiment geben wir auf Anfrage bekannt.

KOTURASTA GLODALA ZA ŽLJEBOVE,  
SA PRAVIM PODSTRUGANIM ZUBIMA

SLOTING CUTTERS,  
WITH STRAIGHT TEETH FORM-RELIEVED

NUTENFRÄSER,  
GERADEVERZAHNT HINTERDREHT

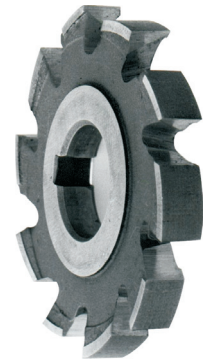
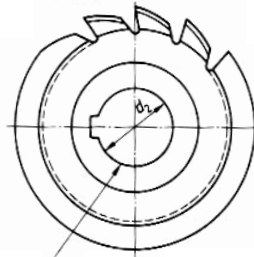
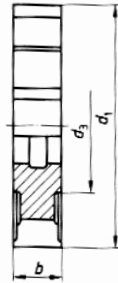

Series					SG131	SG132
	Material				HSS	Co 5%
	Form				A	A
	d <sub>1</sub>	b	d <sub>2</sub>	d <sub>3</sub>	price EUR	
	js16	d9	H7	min.	each	each
050004	50	4	16	27	36,800	46,000
050005	50	5	16	27	36,800	46,000
050006	50	6	16	27	38,400	48,000
050008	50	8	16	27	42,000	52,500
050010	50	10	16	27	45,600	57,000
063004	63	4	22	34	50,000	62,500
063005	63	5	22	34	50,000	62,500
063006	63	6	22	34	52,000	65,000
063008	63	8	22	34	56,800	71,000
063010	63	10	22	34	61,600	77,000
063012	63	12	22	34	67,200	84,000
063014	63	14	22	34	72,000	90,000
080005	80	5	27	41	68,000	85,000
080006	80	6	27	41	70,800	88,500
080008	80	8	27	41	77,200	96,500
080010	80	10	27	41	84,000	105,000
080012	80	12	27	41	91,600	114,500
080014	80	14	27	41	98,000	122,500
080016	80	16	27	41	106,800	133,500
080018	80	18	27	41	114,800	143,500
100006	100	6	32	47	95,600	119,500
100008	100	8	32	47	104,800	131,000
100010	100	10	32	47	113,600	142,000
100012	100	12	32	47	124,000	155,000
100014	100	14	32	47	132,800	166,000
100016	100	16	32	47	143,200	179,000
100018	100	18	32	47	154,400	193,000
100020	100	20	32	47	164,800	206,000
100022	100	22	32	47	174,800	218,500
100025	100	25	32	47	198,000	247,500

\*Posebno označene cijene ( **bold** ) odnose se na robu koju imamo na lageru. Za ostali asortiman rabate i rokove isporuke dajemo na osnovu upita.

\*Prices given in **bold** figures refer to products on stock. Discount and delivery terms for other product assortment are given at request.

\*Die separat gekennzeichneten Prices ( **bold** ) beziehen sich auf die Ware, die auf Lager liegt. Die Rabatte und Lieferzeiten für das restliche Sortiment geben wir auf Anfrage bekannt.



Series					SG131	SG132
	Material				HSS	Co 5%
	Form				A	A
	d <sub>1</sub>	b	d <sub>2</sub>	d <sub>3</sub>	price EUR	
js16	d9	H7	min.	each	each	
125008	125	8	32	47	157,200	196,500
125010	125	10	32	47	170,400	213,000
125012	125	12	32	47	186,000	232,500
125014	125	14	32	47	198,400	248,000
125016	125	16	32	47	214,800	268,500
125018	125	18	32	47	233,600	292,000
125020	125	20	32	47	250,800	313,500
125022	125	22	32	47	268,800	336,000
125025	125	25	32	47	296,800	371,000
160010	160	10	40	55	256,000	320,000
160012	160	12	40	55	279,200	349,000
160014	160	14	40	55	300,000	375,000
160016	160	16	40	55	328,000	410,000
160018	160	18	40	55	356,800	446,000
160020	160	20	40	55	383,200	479,000
160022	160	22	40	55	410,400	513,000
160025	160	25	40	55	453,200	566,500
160028	160	28	40	55	496,800	621,000
160032	160	32	40	55	540,000	675,000

\*Posebno označene cijene ( **bold** ) odnose se na robu koju imamo na lageru. Za ostali asortiman rabate i rokove isporuke dajemo na osnovu upita.

\*Prices given in **bold** figures refer to products on stock. Discount and delivery terms for other product assortment are given at request.

\*Die separat gekennzeichneten Prices ( **bold** ) beziehen sich auf die Ware, die auf Lager liegt. Die Rabatte und Lieferzeiten für das restliche Sortiment geben wir auf Anfrage bekannt.



**KOTURASTA GLODALA ZA ŽLJEBOVE  
SA UKRŠTENIM PODSTRUGANIM ZUBIMA**

**SLOTING CUTTERS  
WITH STAGGERD TEETH FORM-RELIEVED**

**NUTENFRÄSER  
KREUZVERZAHNT HINTERDREHT**

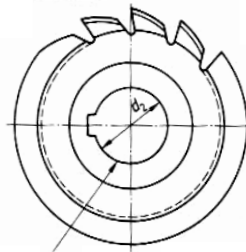
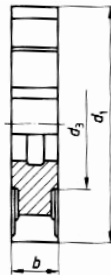

Series					SG133	SG134
	Material				HSS	Co 5%
	Form				B	B
	d <sub>1</sub>	b	d <sub>2</sub>	d <sub>3</sub>	price EUR	
	js16	d9	H7	min.	each	each
050004	50	4	16	27	33,600	42,000
050005	50	5	16	27	34,800	43,500
050006	50	6	16	27	36,400	45,500
050008	50	8	16	27	40,400	50,500
050010	50	10	16	27	44,000	55,000
063004	63	4	22	34	45,600	57,000
063005	63	5	22	34	48,000	60,000
063006	63	6	22	34	50,000	62,500
063008	63	8	22	34	54,800	68,500
063010	63	10	22	34	59,600	74,500
063012	63	12	22	34	76,800	96,000
063014	63	14	22	34	82,400	103,000
080005	80	5	27	41	62,000	77,500
080006	80	6	27	41	64,800	81,000
080008	80	8	27	41	70,800	88,500
080010	80	10	27	41	82,400	103,000
080012	80	12	27	41	88,800	111,000
080014	80	14	27	41	95,600	119,500
080016	80	16	27	41	104,800	131,000
080018	80	18	27	41	112,000	140,000
100006	100	6	32	47	82,800	103,500
100008	100	8	32	47	90,400	113,000
100010	100	10	32	47	105,200	131,500
100012	100	12	32	47	117,600	147,000
100014	100	14	32	47	129,600	162,000
100016	100	16	32	47	140,400	175,500
100018	100	18	32	47	151,200	189,000
100020	100	20	32	47	161,600	202,000
100022	100	22	32	47	172,000	215,000
100025	100	25	32	47	188,800	236,000

\*Posebno označene cijene ( **bold** ) odnose se na robu koju imamo na lageru. Za ostali asortiman rabate i rokove isporuke dajemo na osnovu upita.

\*Prices given in **bold** figures refer to products on stock. Discount and delivery terms for other product assortment are given at request.

\*Die separat gekennzeichneten Prices ( **bold** ) beziehen sich auf die Ware, die auf Lager liegt. Die Rabatte und Lieferzeiten für das restliche Sortiment geben wir auf Anfrage bekannt.

Series					SG133	SG134
	Material				HSS	Co 5%
	Form				B	B
	d <sub>1</sub>	b	d <sub>2</sub>	d <sub>3</sub>	price EUR	
js16	d9	H7	min.	each	each	
125008	125	8	32	47	133,600	167,000
125010	125	10	32	47	157,200	196,500
125012	125	12	32	47	176,000	220,000
125014	125	14	32	47	192,800	241,000
125016	125	16	32	47	210,400	263,000
125018	125	18	32	47	228,000	285,000
125020	125	20	32	47	245,200	306,500
125022	125	22	32	47	264,800	331,000
125025	125	25	32	47	290,800	363,500
160010	160	10	40	55	246,000	307,500
160012	160	12	40	55	275,600	344,500
160014	160	14	40	55	301,600	377,000
160016	160	16	40	55	331,200	414,000
160018	160	18	40	55	356,800	446,000
160020	160	20	40	55	384,000	480,000
160022	160	22	40	55	414,400	518,000
160025	160	25	40	55	455,200	569,000
160028	160	28	40	55	496,800	621,000
160032	160	32	40	55	540,000	675,000

\*Posebno označene cijene ( **bold** ) odnose se na robu koju imamo na lageru. Za ostali asortiman rabate i rokove isporuke dajemo na osnovu upita.

\*Prices given in **bold** figures refer to products on stock. Discount and delivery terms for other product assortment are given at request.

\*Die separat gekennzeichneten Prices ( **bold** ) beziehen sich auf die Ware, die auf Lager liegt. Die Rabatte und Lieferzeiten für das restliche Sortiment geben wir auf Anfrage bekannt.

ČETVEROKRUŽNA UDUBLJENA GLODALA

CORNER ROUNDING CUTTERS

VIERTEILRUND PROFILFRÄSER (KONKAV)

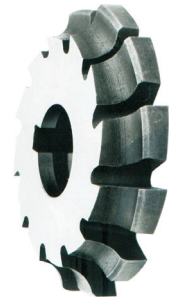
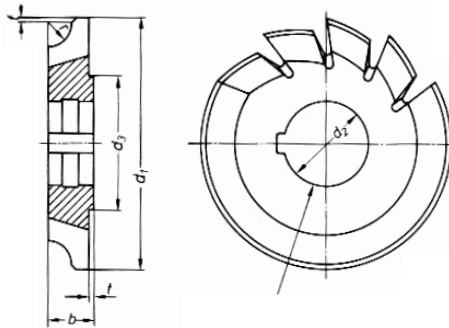

Series	Material							SG137	SG138
	r	d <sub>1</sub>	d <sub>2</sub>	d <sub>3</sub>	b	f	t	HSS	Co 5%
	h11	js16	H7					price EUR	
100050	1	50	16		4	0,2		32,400	40,500
125050	1,25	50	16		4	0,2		33,000	41,250
160050	1,6	50	16		5	0,25		35,880	44,850
200050	2	50	16		5	0,25		36,400	45,500
250063	2,5	63	22		5	0,3		42,680	53,350
300063	3	63	22		6	0,3		47,640	59,550
315063	3,15	63	22		6	0,3		49,000	61,250
400063	4	63	22		8	0,4		56,840	71,050
500063	5	63	22		10	0,5		63,200	79,000
600080	6	80	27	41	12	0,6	0,5	89,400	111,750
630080	6,3	80	27	41	12	0,6	0,5	93,800	117,250
800080	8	80	27	41	16	0,8	0,5	113,480	141,850
100100	10	100	32	47	18	1	0,5	169,800	212,250
120100	12	100	32	47	20	1,2	0,5	192,080	240,100
125100	12,5	100	32	47	20	1,2	0,5	195,400	244,250
160125	16	125	32	47	24	1,6	0,5	305,920	382,400
200125	20	125	32	47	28	2	0,5	352,600	440,750

\*Posebno označene cijene ( **bold** ) odnose se na robu koju imamo na lageru. Za ostali asortiman rabate i rokove isporuke dajemo na osnovu upita.

\*Prices given in **bold** figures refer to products on stock. Discount and delivery terms for other product assortment are given at request.

\*Die separat gekennzeichneten Prices ( **bold** ) beziehen sich auf die Ware, die auf Lager liegt. Die Rabatte und Lieferzeiten für das restliche Sortiment geben wir auf Anfrage bekannt.

**GLODALA SA JEDNIM ŽLJEBOM ZA ALUMINIJUM I PVC**

**2 FLUTE ENDMILLS FOR ALUMINIUM AND PVC**

**AINZAHNFRÄSER VON ALUMINIUM UND PVC**

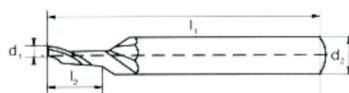

Series	Material				SG151	SG152
	d <sub>1</sub>	l <sub>1</sub>	d <sub>2</sub>	l <sub>2</sub>	HSS	Co 5%
	mm	mm	mm	mm	price EUR	
					each	each
	3	60	6	12	10,000	12,500
	3	60	8	12	10,000	12,500
	4	60	6	12	10,000	12,500
	4	60	8	12	10,000	12,500
	5	60	6	12	10,000	12,500
	5	60	8	12	10,000	12,500
	6	60	6	14	10,000	12,500
	6	60	8	14	10,000	12,500
	8	80	8	15	12,000	15,000
	10	80	10	15	12,600	15,750

**GLODALA SA JEDNIM ŽLJEBOM, DUGA ZA ALUMINIJUM I PVC**

**2 FLUTE ENDMILLS, LONG FOR ALUMINIUM AND PVC**

**AINZAHNFRÄSER, LANGE VON ALUMINIUM UND PVC**



Series	Material					SG153	SG154
	d <sub>1</sub>	l <sub>1</sub>	d <sub>2</sub>	l <sub>2</sub>	l <sub>3</sub>	HSS	Co 5%
	mm	mm	mm	mm	mm	price EUR	
						each	each
	4	80	8	16	29	12,000	15,000
	5	80	8	16	29	12,000	15,000
	6	90	8	16	29	12,600	15,750
	8	100	8	30	40	14,000	17,500

\*Posebno označene cijene ( **bold** ) odnose se na robu koju imamo na lageru. Za ostali asortiman rabate i rokove isporuke dajemo na osnovu upita.

\*Prices given in **bold** figures refer to products on stock. Discount and delivery terms for other product assortment are given at request.

\*Die separat gekennzeichneten Prices ( **bold** ) beziehen sich auf die Ware, die auf Lager liegt. Die Rabatte und Lieferzeiten für das restliche Sortiment geben wir auf Anfrage bekannt.

**GLODALA ZA RUPE SA WELDON DRŠKOM (3/4"),  
ZA MAŠINE SA ELEKTROMAGNETIM POSTOLJEM**

**ANNULAR CUTTERS WITH WELDON SHANK (3/4"),  
FOR MACHINE WITH ELEKTORMAGNETIC STAND**

**KERNBOHRER MIT WELDONSCHAFT (3/4"),  
FÜR MAGNETSTÄNDERBOHRMACHINEN**

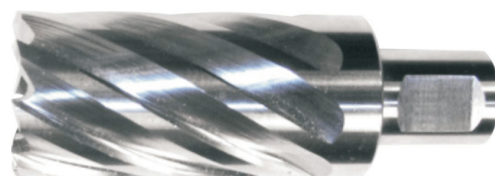

Series	SG161		SG162		SG163		SG164		SG165		SG166	
	Material				HSS						HSS - Co 5%	
	Cutting depth (l <sub>1</sub> , mm)				25	50	75	25	50	75		
	d <sub>1</sub> mm	d <sub>2</sub> mm	l <sub>2</sub> mm	Number of teeth	price EUR							
				each	each	each	each	each	each	each		
012004	12	19	23	4	34,400	42,000	65,100	44,720	54,600	84,630		
013004	13	19	23	4	34,400	42,000	65,100	44,720	54,600	84,630		
014004	14	19	23	4	34,400	42,000	65,100	44,720	54,600	84,630		
015004	15	19	23	4	34,400	42,000	65,100	44,720	54,600	84,630		
016005	16	19	23	5	35,200	42,800	66,340	45,760	55,640	86,242		
017005	17	19	23	5	35,200	42,800	66,340	45,760	55,640	86,242		
018005	18	19	23	5	35,200	42,800	66,340	45,760	55,640	86,242		
019005	19	19	23	5	35,200	42,800	66,340	45,760	55,640	86,242		
020006	20	19	23	6	35,800	44,800	69,440	46,540	58,240	90,272		
021006	21	19	23	6	37,200	46,800	72,540	48,360	60,840	94,302		
022006	22	19	23	6	38,600	49,200	76,260	50,180	63,960	99,138		
023006	23	19	23	6	40,400	51,600	79,980	52,520	67,080	103,974		
024006	24	19	23	6	42,800	53,200	82,460	55,640	69,160	107,198		
025006	25	19	23	6	44,000	56,000	86,800	57,200	72,800	112,840		
026007	26	19	23	7	46,400	59,600	92,380	60,320	77,480	120,094		
027007	27	19	23	7	48,800	61,600	95,480	63,440	80,080	124,124		
028007	28	19	23	7	50,000	64,400	99,820	65,000	83,720	129,766		
029008	29	19	23	8	54,000	69,200	107,260	70,200	89,960	139,438		
030008	30	19	23	8	56,000	71,600	110,980	72,800	93,080	144,274		
031008	31	19	23	8	58,400	74,000	114,700	75,920	96,200	149,110		
032008	32	19	23	8	60,800	77,600	120,280	79,040	100,880	156,364		
033008	33	19	23	8	62,800	80,400	124,620	81,640	104,520	162,006		
034008	34	19	23	8	64,800	83,200	128,960	84,240	108,160	167,648		
035009	35	19	23	9	68,800	88,400	137,020	89,440	114,920	178,126		
036009	36	19	23	9	72,000	91,600	141,980	93,600	119,080	184,574		
037009	37	19	23	9	74,800	94,800	146,940	97,240	123,240	191,022		
038010	38	19	23	10	79,200	102,000	158,100	102,960	132,600	205,530		
039010	39	19	23	10	82,000	104,800	162,440	106,600	136,240	211,172		
040010	40	19	23	10	84,800	107,600	166,780	110,240	139,880	216,814		
041010	41	19	23	10	87,600	111,200	172,360	113,880	144,560	224,068		
042012	42	19	23	12	92,800	120,400	186,620	120,640	156,520	242,606		
043012	43	19	23	12	96,000	124,000	192,200	124,800	161,200	249,860		
044012	44	19	23	12	98,800	127,200	197,160	128,440	165,360	256,308		
045012	45	19	23	12	99,600	131,600	203,980	129,480	171,080	265,174		
046012	46	19	23	12	105,600	136,000	210,800	137,280	176,800	274,040		

\*Posebno označene cijene ( **bold** ) odnose se na robu koju imamo na lageru. Za ostali asortiman rabate i rokove isporuke dajemo na osnovu upita.

\*Prices given in **bold** figures refer to products on stock. Discount and delivery terms for other product assortment are given at request.

\*Die separat gekennzeichneten Prices ( **bold** ) beziehen sich auf die Ware, die auf Lager liegt. Die Rabatte und Lieferzeiten für das restliche Sortiment geben wir auf Anfrage bekannt.

Series					SG161	SG162	SG163	SG164	SG165	SG166
	Material				HSS			HSS - Co 5%		
	Cutting depth (l <sub>1</sub> mm)				25	50	75	25	50	75
	d <sub>1</sub>	d <sub>2</sub>	l <sub>2</sub>	Number	price EUR					
mm	mm	mm	of teeth	each	each	each	each	each	each	
047012	47	19	23	12	108,800	139,600	216,380	141,440	181,480	281,294
048012	48	19	23	12	111,600	144,000	223,200	145,080	187,200	290,160
049012	49	19	23	12	115,600	148,800	230,640	150,280	193,440	299,832
050012	50	19	23	12	118,800	154,400	239,320	154,440	200,720	311,116
051012	51	19	23	12	122,400	160,000	248,000	159,120	208,000	322,400
052012	52	19	23	12	126,000	164,000	254,200	163,800	213,200	330,460
053012	53	19	23	12	130,000	168,400	261,020	169,000	218,920	339,326
054012	54	19	23	12	133,600	172,800	267,840	173,680	224,640	348,192
055012	55	19	23	12	137,200	177,600	275,280	178,360	230,880	357,864
056012	56	19	23	12	140,800	182,800	283,340	183,040	237,640	368,342
057012	57	19	23	12	145,200	186,400	288,920	188,760	242,320	375,596
058012	58	19	23	12	149,600	193,200	299,460	194,480	251,160	389,298
059012	59	19	23	12	152,800	196,800	305,040	198,640	255,840	396,552
060012	60	19	23	12	157,200	204,000	316,200	204,360	265,200	411,060

\*Posebno označene cijene ( **bold** ) odnose se na robu koju imamo na lageru. Za ostali asortiman rabate i rokove isporuke dajemo na osnovu upita.

\*Prices given in **bold** figures refer to products on stock. Discount and delivery terms for other product assortment are given at request.

\*Die separat gekennzeichneten Prices ( **bold** ) beziehen sich auf die Ware, die auf Lager liegt. Die Rabatte und Lieferzeiten für das restliche Sortiment geben wir auf Anfrage bekannt.



**PROBIJAČI RUPA SA ZAVRTNJEM, SA 3 REZNA VRHA**

**SCREW HOLE - PUNCHES, WITH 3 POINT CUTTING**

**SCHRAUBLOCHSTANZEN, MIT 3 PUNKT ANCHNITT**

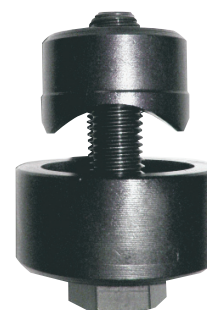

Series					SG181	SG182
	Material				Spec. steel	Spec. steel
	Type				A	B
					Standard	Ball-bearing
	Ø	Pg	Screw	Metal sheet	price EUR	
	mm		MF	max.mm	each	each
000127	12,7	7	8x1	1,5	12,400	20,000
000130	13	-	8x1	1,5	12,800	20,400
000140	14	-	8x1	1,5	13,200	20,800
000150	15	-	8x1	1,5	13,200	20,800
000152	15,2	9	10x1	1,5	13,200	20,800
000160	16	-	10x1	2	13,200	20,800
000165	16,5	-	10x1	2	13,200	20,800
000170	17	-	10x1	2	13,200	20,800
000180	18	-	10x1	2	13,600	21,200
000186	18,6	11	10x1	2	14,400	22,000
000190	19	-	10x1	2	14,400	22,000
000200	20	-	10x1	2	14,400	22,000
000204	20,4	13,5	10x1	2	14,800	22,400
000210	21	-	10x1	2	14,800	22,400
000220	22	-	10x1	2	15,200	22,800
000225	22,5	16	10x1	2	15,200	22,800
000230	23	-	10x1	2	15,200	22,800
000240	24	-	10x1	2	15,200	22,800
000250	25	-	10x1	2	16,000	23,600
000254	25,4	-	10x1	2	16,000	23,600
000260	26	-	10x1	2	16,000	23,600
000270	27	-	10x1	2	16,000	23,600
000280	28	-	12x1,5	2	16,400	24,000
000283	28,3	21	12x1,5	2	16,400	24,000
000290	29	-	12x1,5	2	16,400	24,000
000300	30	-	12x1,5	2	17,200	24,800
000305	30,5	-	12x1,5	2	17,200	24,800
000310	31	-	12x1,5	2	17,200	24,800
000320	32	-	12x1,5	2	18,400	26,000
000325	32,5	-	12x1,5	2	18,400	26,000
000330	33	-	12x1,5	2	18,800	26,400
000340	34	-	12x1,5	2	19,600	27,200
000350	35	-	12x1,5	2	20,400	28,000
000360	36	-	12x1,5	2	20,400	28,000
000370	37	29	12x1,5	2	20,800	28,400
000380	38	-	12x1,5	2	21,200	28,800
000390	39	-	12x1,5	2	22,400	30,000
000400	40	-	12x1,5	2	22,400	30,000

\*Posebno označene cijene ( **bold** ) odnose se na robu koju imamo na lageru. Za ostali asortiman rabate i rokove isporuke dajemo na osnovu upita.

\*Prices given in **bold** figures refer to products on stock. Discount and delivery terms for other product assortment are given at request.

\*Die separat gekennzeichneten Prices ( **bold** ) beziehen sich auf die Ware, die auf Lager liegt. Die Rabatte und Lieferzeiten für das restliche Sortiment geben wir auf Anfrage bekannt.

Series					SG181	SG182
	Material				Spec. steel	Spec. steel
	Type				A	B
					Standard	Ball-bearing
	Ø	Pg	Screw	Metal sheet	price EUR	
	mm		MF	max.mm	each	each
000405	40,5	-	16x1,5	2	22,400	30,000
000410	41	-	16x1,5	2	23,200	30,800
000420	42	-	16x1,5	2	23,200	30,800
000430	43	-	16x1,5	2	23,200	30,800
000440	44	-	16x1,5	2	24,000	31,600
000450	45	-	16x1,5	2	24,000	31,600
000460	46	-	16x1,5	2	24,000	31,600
000470	47	36	16x1,5	2	27,200	34,800
000480	48	-	16x1,5	2	27,200	34,800
000490	49	-	16x1,5	2	27,200	34,800
000500	50	-	16x1,5	2	28,000	35,600
000505	50,5	-	16x1,5	3	30,000	37,600
000510	51	-	16x1,5	3	31,600	39,200
000520	52	-	16x1,5	3	32,000	39,600
000525	52,5	-	16x1,5	3	33,600	41,200
000530	53	-	16x1,5	3	33,600	41,200
000540	54	42	16x1,5	3	36,800	44,400
000550	55	-	16x1,5	3	38,000	45,600
000560	56	-	16x1,5	3	40,000	47,600
000570	57	-	16x1,5	3	40,000	47,600
000580	58	-	16x1,5	3	40,000	47,600
000590	59	-	16x1,5	3	40,000	47,600
000600	60	48	16x1,5	3	40,000	47,600
000605	60,5	-	16x1,5	3	42,000	49,600
000610	61	-	16x1,5	3		
000620	62	-	16x1,5	3		
000630	63	-	16x1,5	3		
000635	63,5	-	16x1,5	3		
000640	64	-	20x1,5	3		
000650	65	-	20x1,5	3		
000700	70	-	20x1,5	3		
000730	73	-	20x1,5	3,5		
000750	75	-	20x1,5	3,5		
000800	80	-	20x1,5	3,5		
000850	85	-	20x1,5	3,5		
000890	89	-	24x1,5	3,5		
001020	102	-	24x1,5	3,5		
001150	115	-	24x1,5	3,5		

\*Posebno označene cijene ( **bold** ) odnose se na robu koju imamo na lageru. Za ostali asortiman rabate i rokove isporuke dajemo na osnovu upita.

\*Prices given in **bold** figures refer to products on stock. Discount and delivery terms for other product assortment are given at request.

\*Die separat gekennzeichneten Prices ( **bold** ) beziehen sich auf die Ware, die auf Lager liegt. Die Rabatte und Lieferzeiten für das restliche Sortiment geben wir auf Anfrage bekannt.

